



Glade

RESIDENCES

JARO, ILOILO CITY

Glade

RESIDENCES

JARO, ILOILO CITY

Live your dream.



Glade

RESIDENCES

JARO, ILOILO CITY

GLADE RESIDENCES is a modern and complete development that offers convenience and comforts for those who strive and aspire live a better life for themselves and their loved ones.

It is a sub-urban garden home that offers safe, convenient and sustainable community with complete relaxing amenities in an upcoming district ripe for expansion.

It is a home for successful and driven Ilonggo millennials, who wants a new way of living in a fresh and relaxing environment in Iloilo's Jaro District.

Live your dream at Glade Residences!



Glade

RESIDENCES

JARO, ILOILO CITY



ARTIST'S RENDITION

Garden communities that fulfill the aspirations of every Filipino family to live safely, conveniently and comfortably in different progressive areas across the country. This will be the new standard of an upgraded lifestyle by providing sustainable master-planned communities that feature complete facilities and will be professionally managed by a property management company.



Vicinity Map

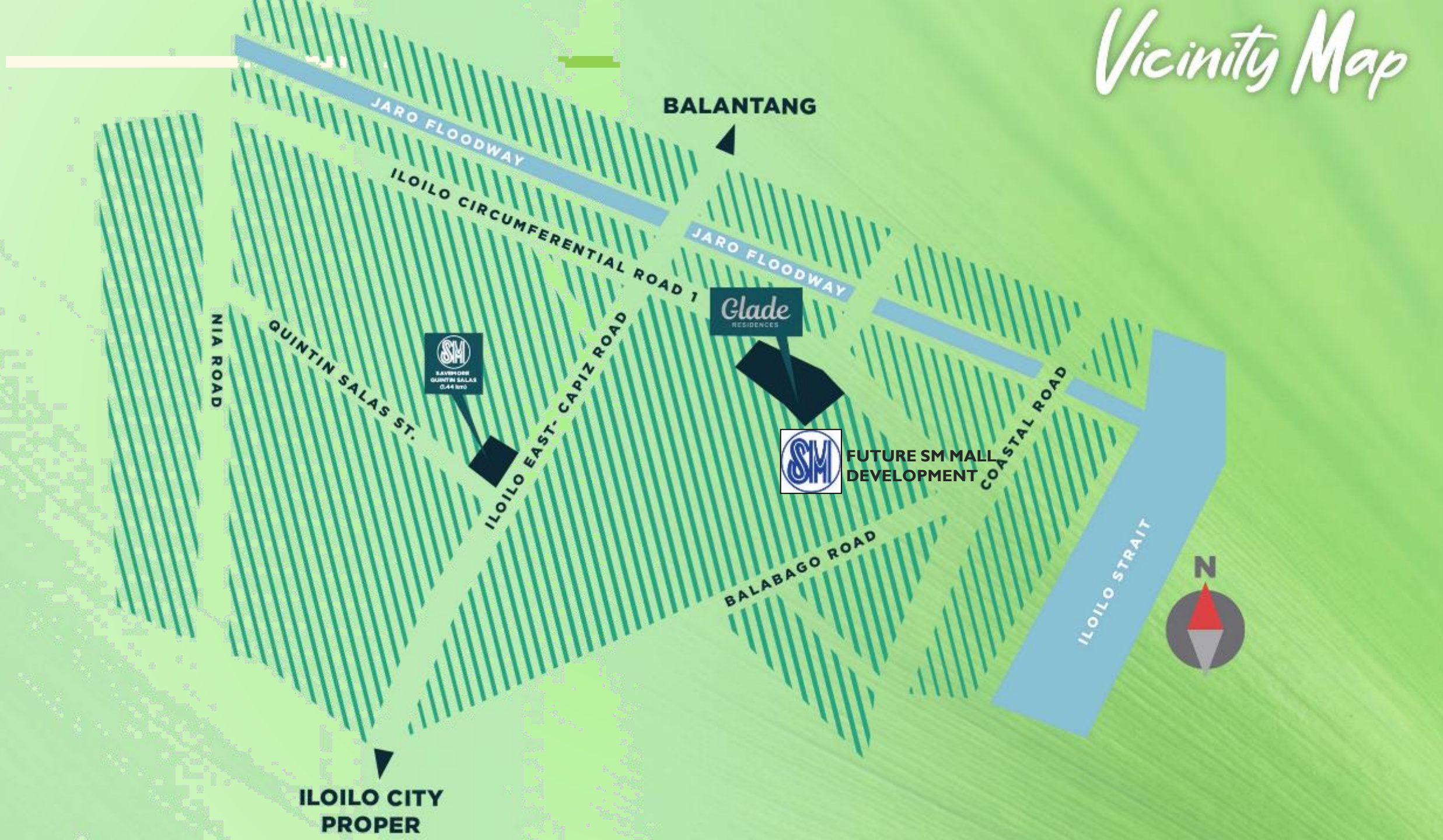

ILOILO CITY – PLACES OF INTEREST

Schools and Universities	Distance
Iloilo Sacred School	2.2km
Huasiang College of Iloilo	2.9km
Filipino - American School Town	3.0km
Angelicum School Iloilo	3.2km
The Great International School	3.2km
Brilliant Mind International School	3.8km
Brilliant Montessori School	3.8km
Colegio de San Jose	4.5km
Central Philippine University	4.5km



Shopping Center / Malls	Distance
Future SM Mall - Jaro	Within the complex
SM Savemore Quentin Salas	2.8km
CityMall Jaro	3.2km
SM Savemore Jaro	4.0km
Robinsons Place Jaro	4.4km
CityMall Pavia	5.2km
Robinsons Place Pavia	5.6km
SM City Iloilo	6.1km



ILOILO CITY – PLACES OF INTEREST

Churches	Distance
Jaro United Methodist Church	3.9km
Jesus Is Lord Church	4.0km
Jaro Metropolitan Cathedral	4.1km
St Joseph The Worker	4.9km
Our Lady of Consolation and St Joseph Church	5.4km

Tourist Spots	Distance
Jaro Plaza	3.8km
National Shrine of Nuestra Senora	3.9km
Nelly's Garden (Heritage House)	4.7km
Iloilo Museum of Contemporary Arts	5.1km
Museo Iloilo	5.3km
Calle Real	6.4km

Hospitals	Distance
Metro Iloilo Hospital and Medical Center	3.6km
Jaro Medical Hospital	4.0km
West Visayas State University Medical Center	5.3km
Iloilo Mission Hospital	6.0km



Site Development Plan

FUTURE



MALL
DEVELOPMENT



- 1 Grand Gateway
- 2 Lobby Lounge
- 3 Function Area
- 4 Kids Zone
- 5 Adult Swimming Pool
- 6 Kids Swimming Pool
- 7 Covered Basketball Court
- 8 Linear Parks
- 9 Green Link

PROJECT DETAILS

	DETAILS
Company	SM Development Corporation (SMDC)
Concept	AFFORDABLE Modern Contemporary Design Residential Development - Mid-rise Residential Development (MRB3) - Second Residential project to be launched in Iloilo
Address	Circumferential Road I, Brgy Balabago, Jaro Iloilo City
Gross Land Area	36,517sqm
FAR	1.5
No. of Buildings	Eleven (11) Mid Rise Buildings - 4 Floors
No. of Residential Units	1,929 units
No. of Parking Slots	314 slots at 1:6 parking ratio
Project Launch	December 2021
Completion Date	May 2026



SMDC GLADE Residences offers flexible unit spaces that caters to young professionals and start-up families

Unit Type	Area	Price
Studio	17.63 sqm	Php 2.5M
Studio End	23.51 sqm	Php 2.94M
1 Bedroom	24.41 sqm	Php 3.05M
1 Bedroom	24.99 sqm	Php 3.12M

BUILDING DETAILS - A

Unit Type	Unit Area (in sqm)	# of Units
I-Bedroom	24.41; 24.99	132
Studio End	23.51	6
Studio	17.63; 18.21	2
TOTAL		140

140 residential units

GF – 26 units per floor

2– 4th Floor – 38 units per floor

KLY PLAN



LEGENDS:

- STUDIO END UNIT
- STUDIO UNIT
- 1 BEDROOM UNIT

Ground Floor

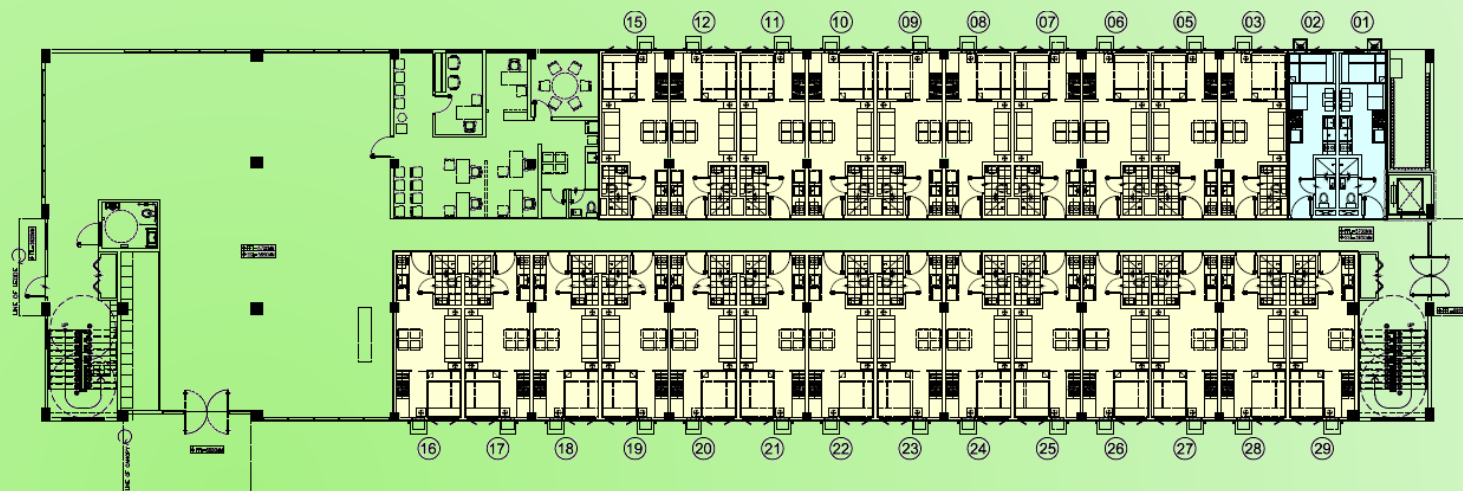

2nd - 4th Floor

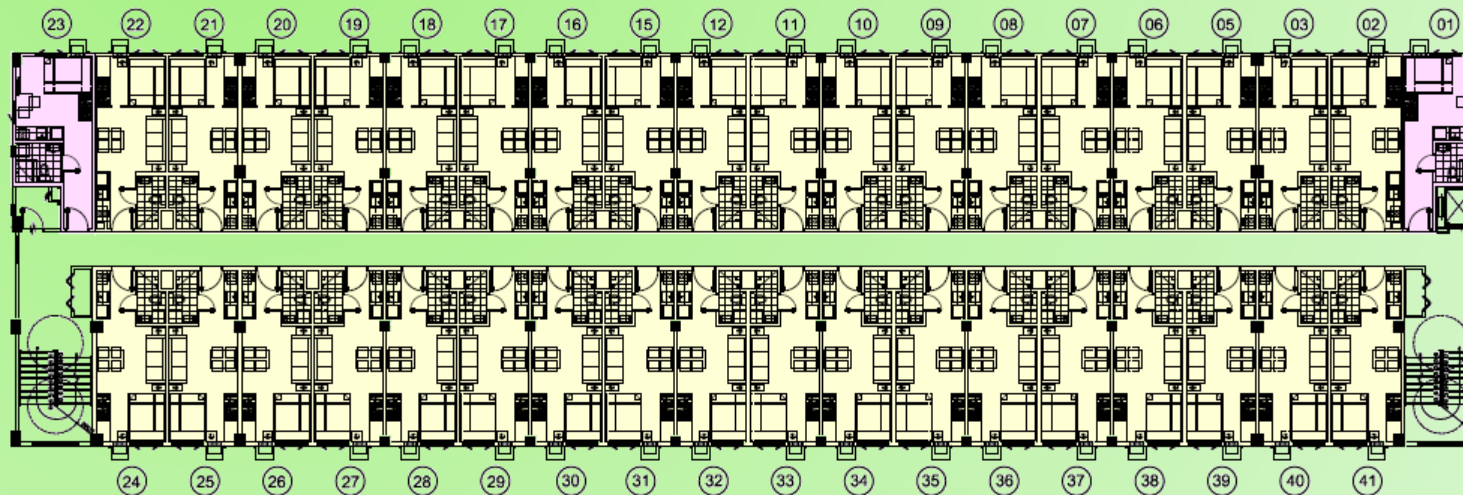

BUILDING DETAILS - E

Unit Type	Unit Area (in sqm)	# of Units
I-Bedroom	24.41; 24.99	175
Studio End	23.51	7
Studio	17.63; 18.21	2
TOTAL		184

- 184 residential units
 - GF – 46 units per floor
 - 2– 4th Floor – 46 units per floor

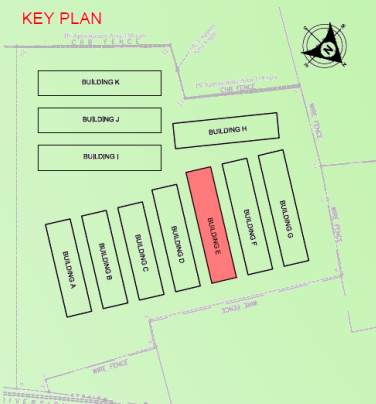

- LEGENDS:**
- STUDIO END UNIT
 - STUDIO UNIT
 - 1 BEDROOM UNIT

Ground Floor

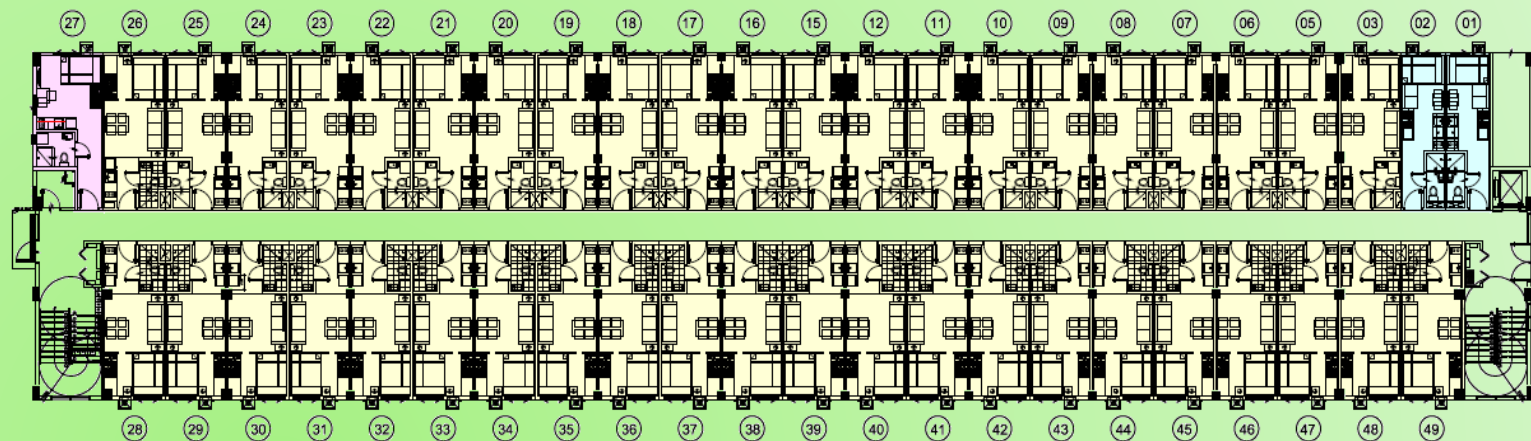

2nd - 4th Floor

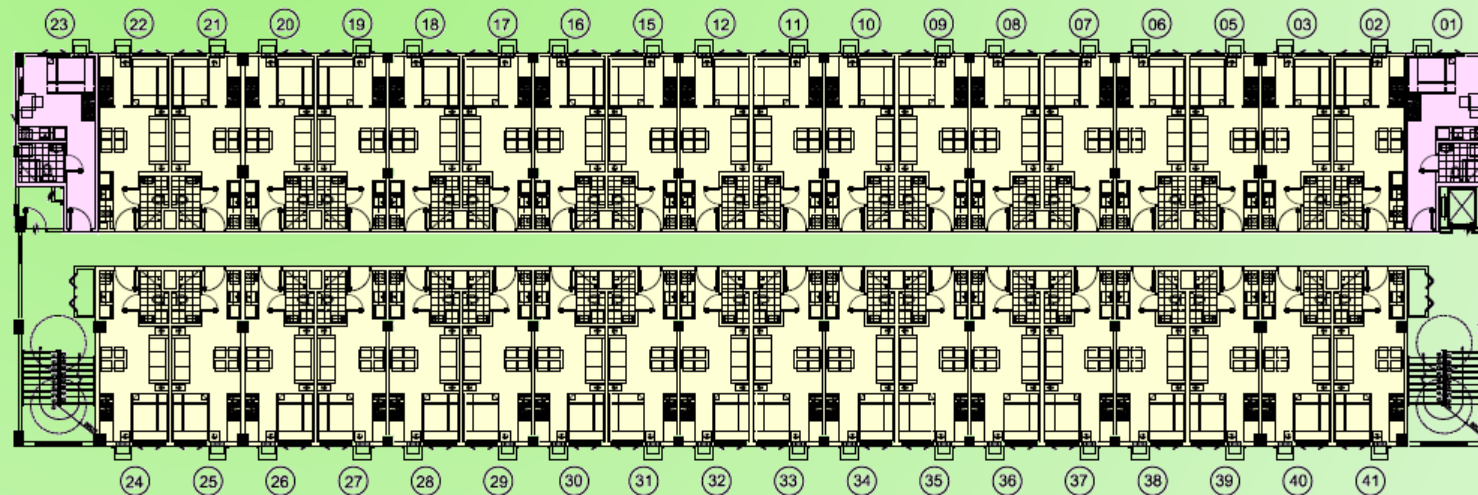

BUILDING DETAILS - F

Unit Type	Unit Area (in sqm)	# of Units
I-Bedroom	24.41; 24.99	176
Studio End	23.51	7
TOTAL		183

Ground Floor

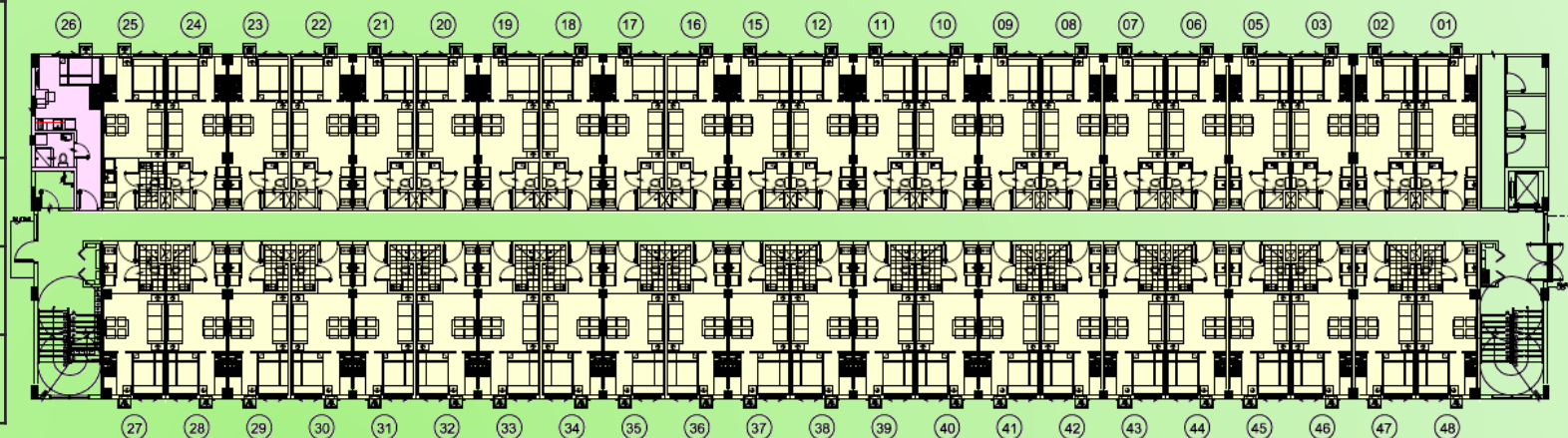

- 183 residential units
- GF – 45 units per floor
- 2– 4th Floor – 46 units per floor

2nd - 4th Floor

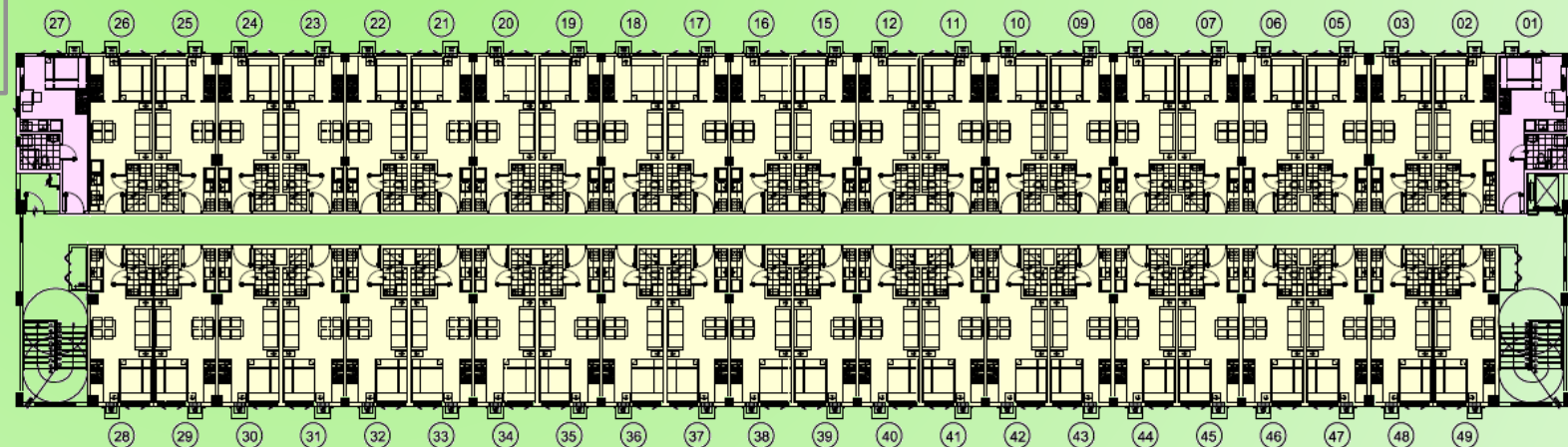

KEY PLAN

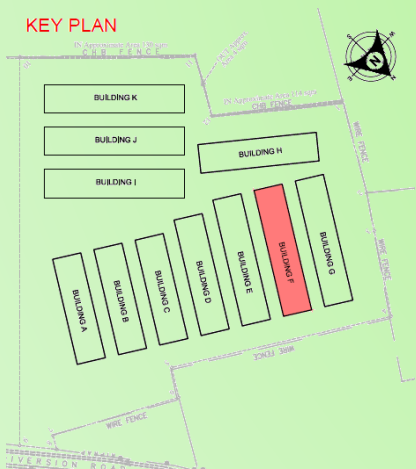

LEGENDS:

- STUDIO END UNIT
- STUDIO UNIT
- 1 BEDROOM UNIT

BUILDING DETAILS - G

Unit Type	Unit Area (in sqm)	# of Units
I-Bedroom	24.41; 24.99	175
Studio End	23.51	7
Studio	17.63; 18.21	2
TOTAL		184

- 184 residential units
 - GF – 46 units per floor
 - 2– 4th Floor – 46 units per floor

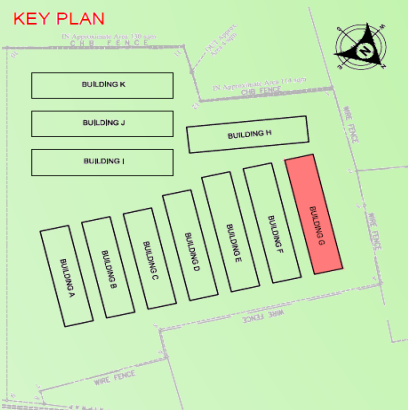

- LEGENDS:**
- STUDIO END UNIT
 - STUDIO UNIT
 - 1 BEDROOM UNIT

Ground Floor

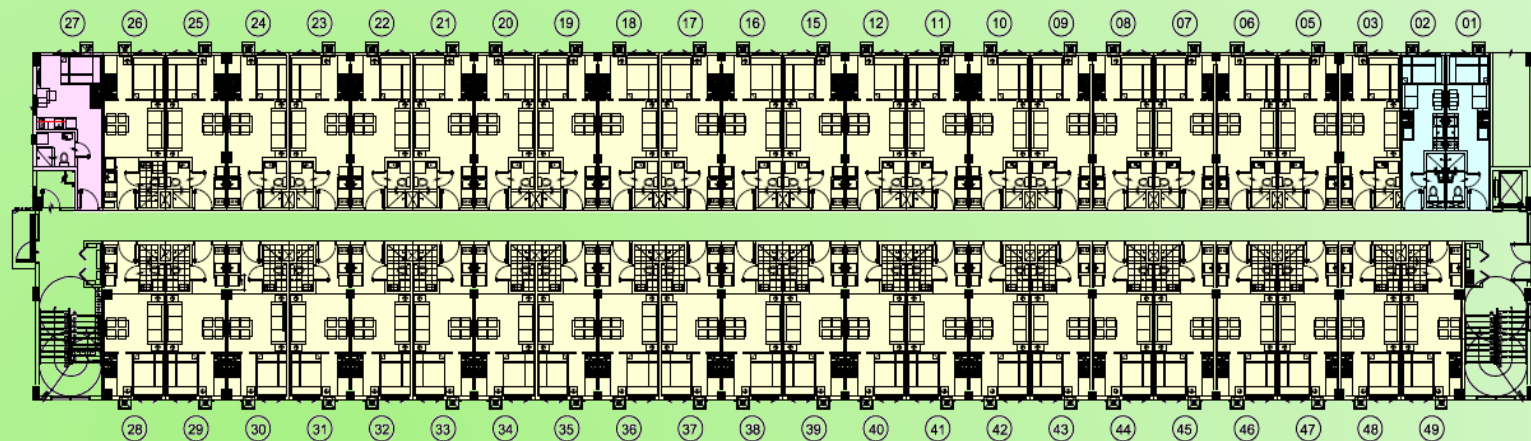

2nd - 4th Floor

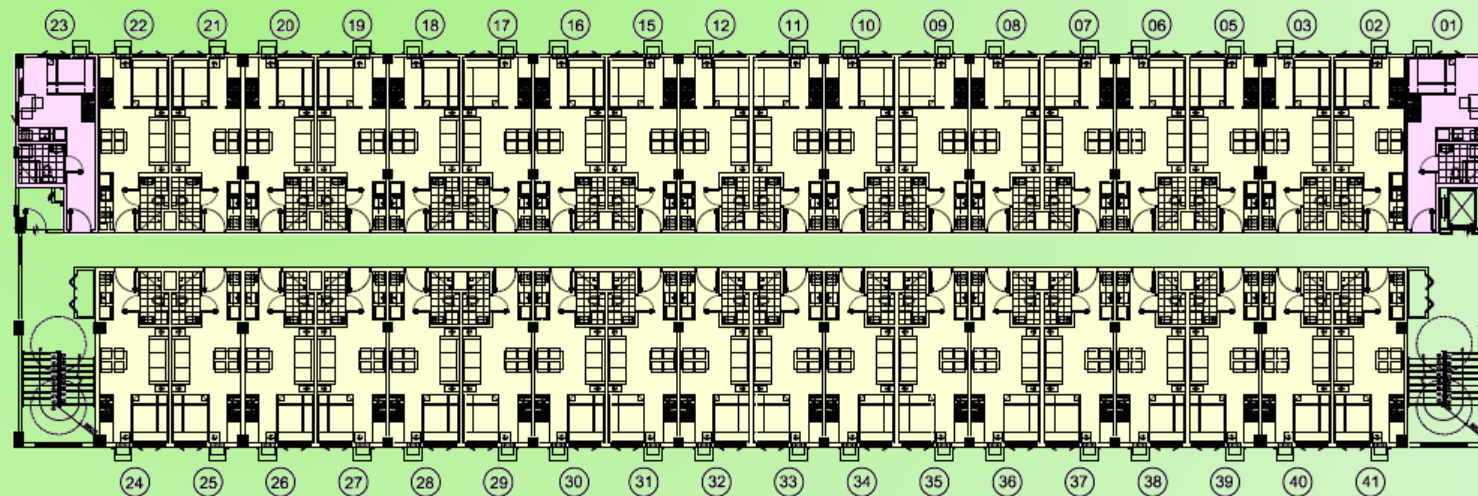

BUILDING DETAILS - H

Unit Type	Unit Area (in sqm)	# of Units
I-Bedroom	24.41; 24.99	159
Studio End	23.51	7
Studio	17.63 to 18.21	2
TOTAL		168

- 200 residential units
 - GF – 42 units per floor
 - 2– 4th Floor – 42 units per floor



LEGENDS:

- STUDIO END UNIT
- STUDIO UNIT
- 1 BEDROOM UNIT

Ground Floor

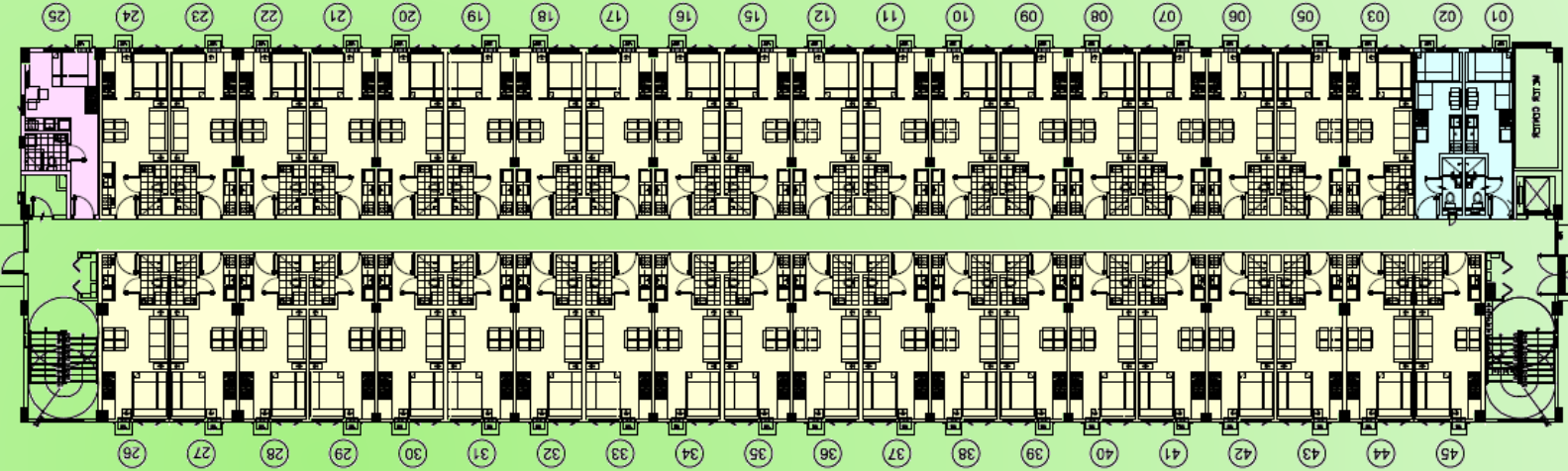

2nd - 4th Floor

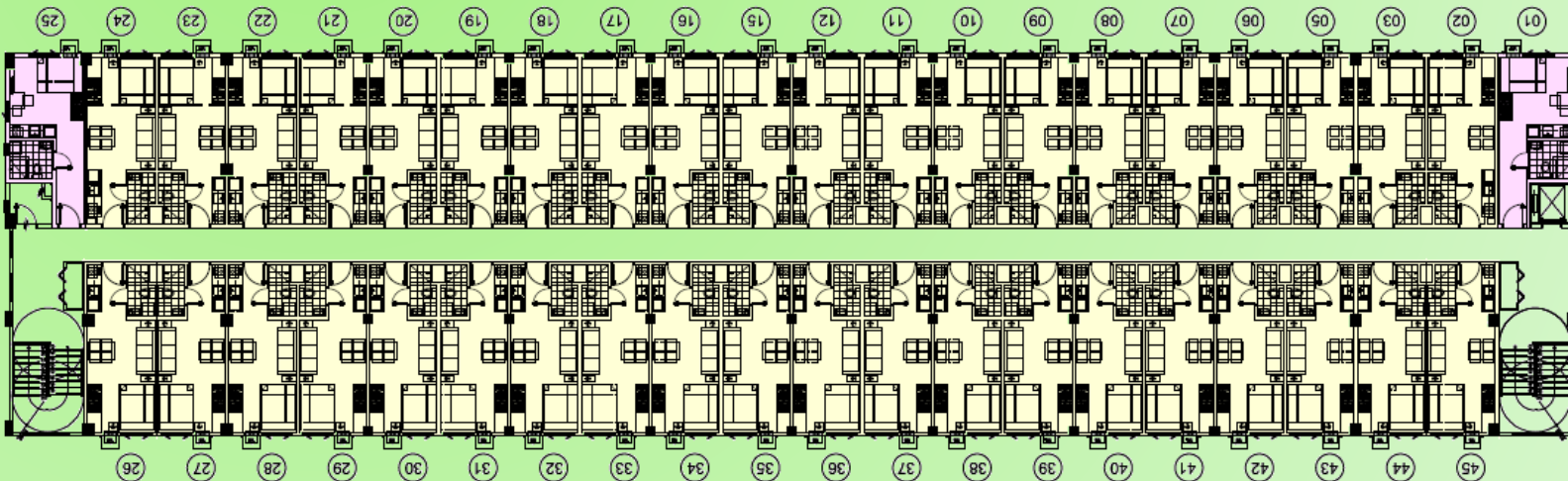

BUILDING DETAILS - I

Unit Type	Unit Area (in sqm)	# of Units
I-Bedroom	24.41; 24.99	191
Studio End	23.51	7
Studio	17.63 to 18.21	2
TOTAL		200

- 200 residential units
 - GF – 50 units per floor
 - 2– 4th Floor – 50 units per floor

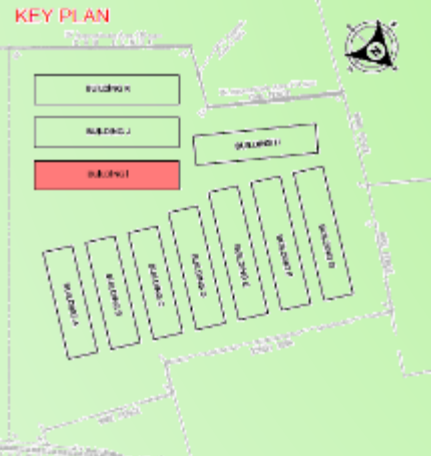

- LEGENDS:
- STUDIO END UNIT
 - STUDIO UNIT
 - 1 BEDROOM UNIT

Ground Floor

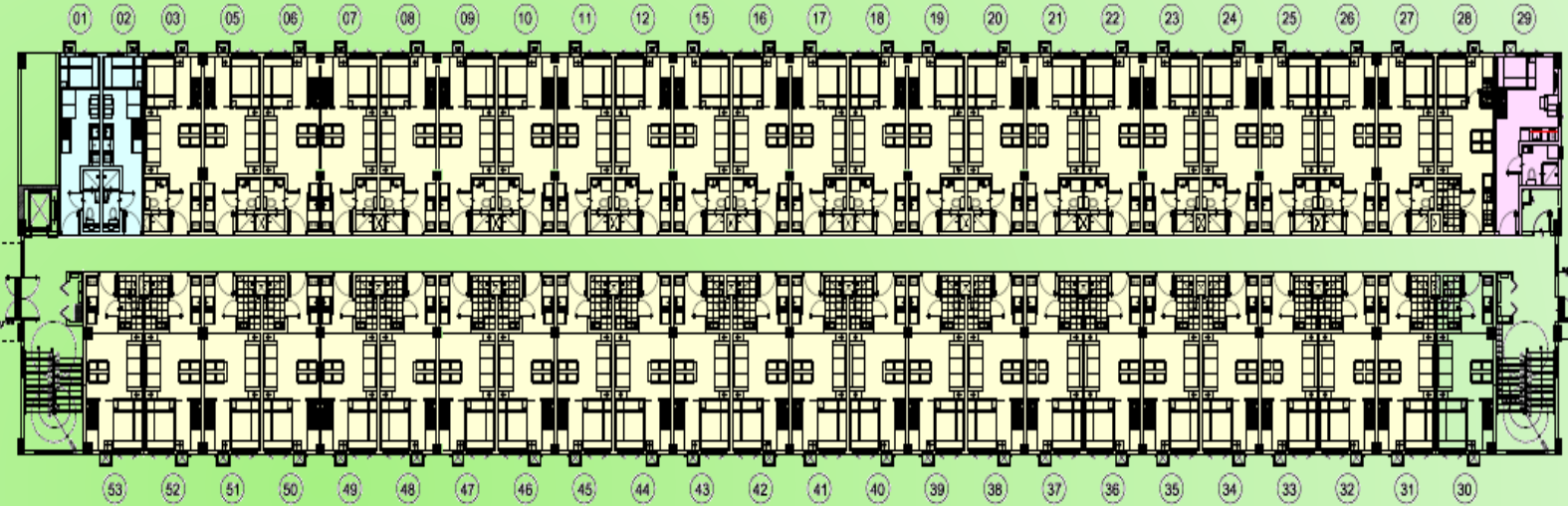

2nd - 4th Floor

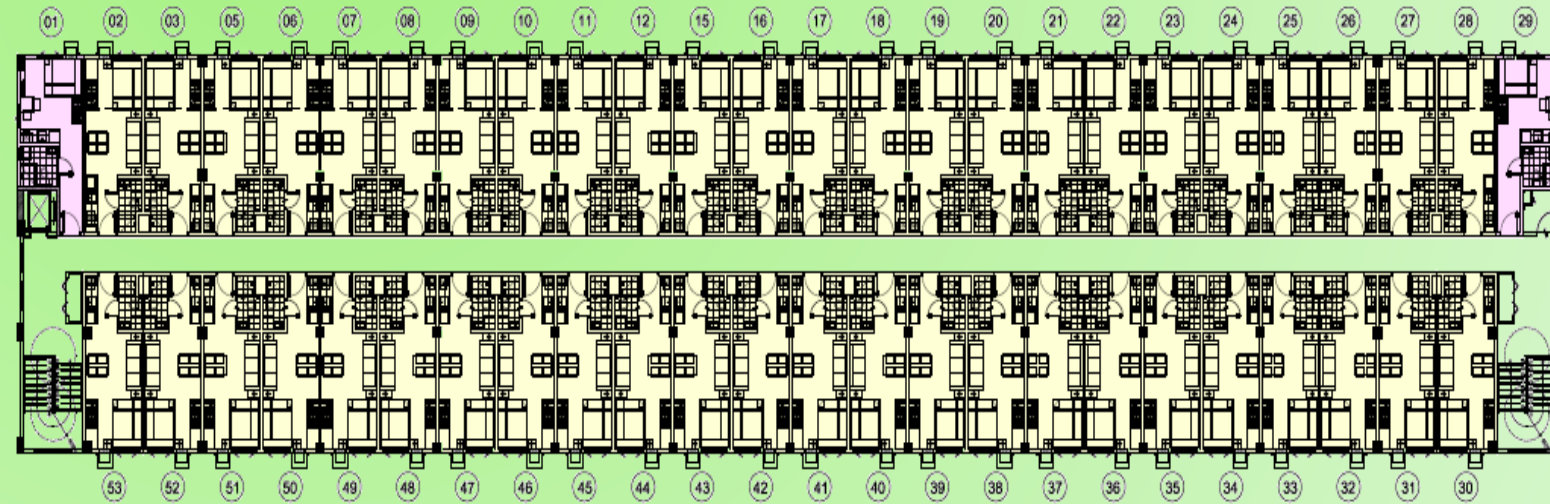

BUILDING DETAILS - J

Unit Type	Unit Area (in sqm)	# of Units
I-Bedroom	24.41; 24.99	192
Studio End	23.51	7
TOTAL		199

- 200 residential units
 - GF – 49 units per floor
 - 2– 4th Floor – 50 units per floor

Ground Floor

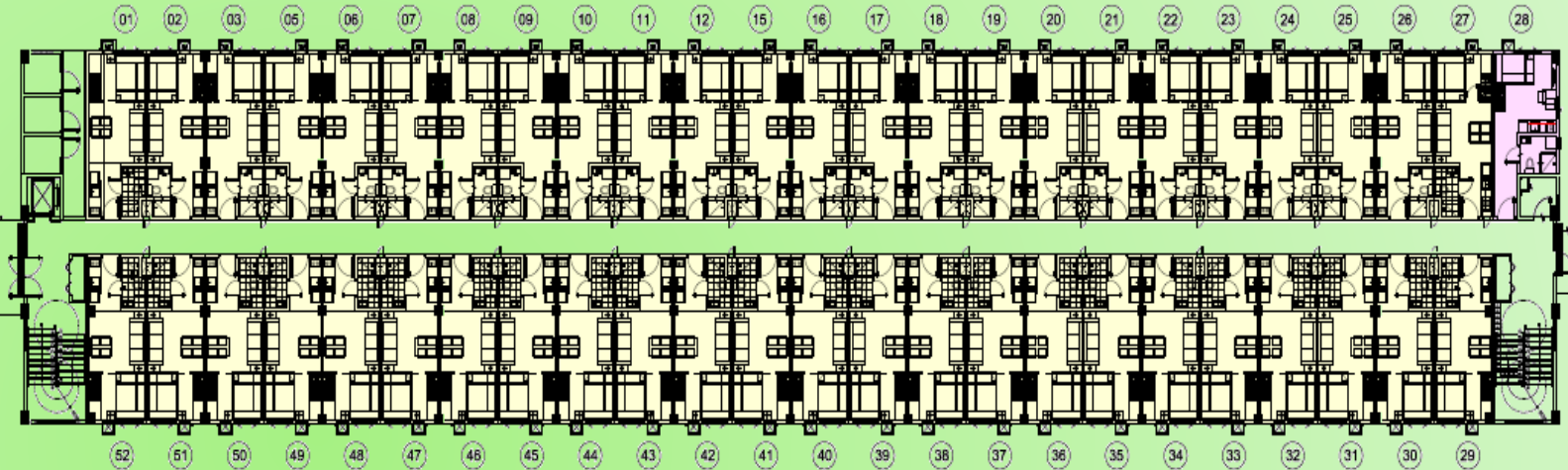

2nd - 4th Floor

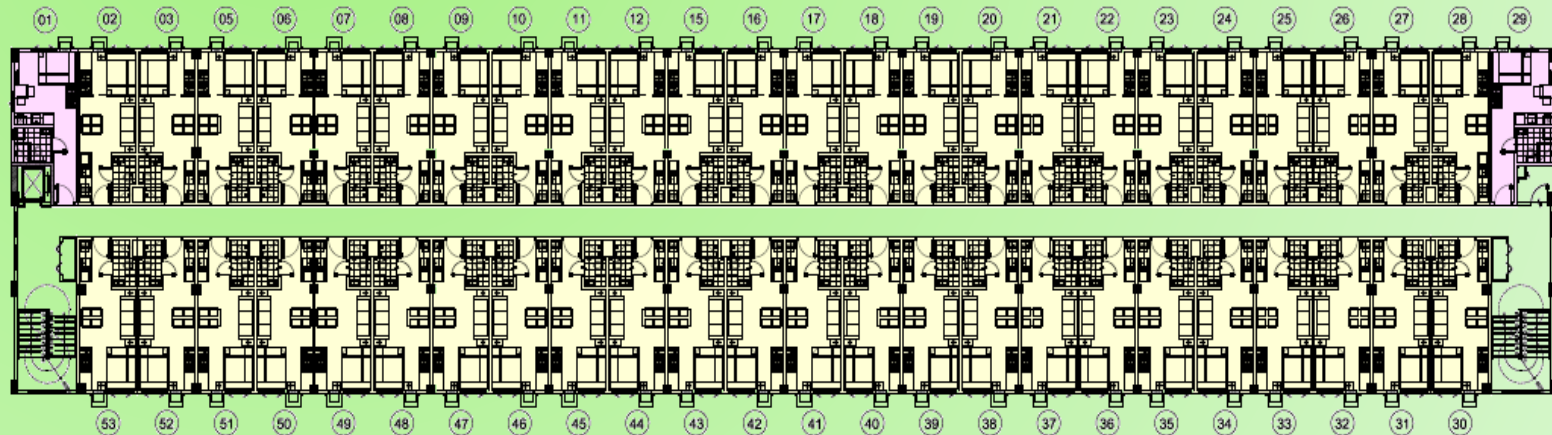

KEY PLAN



LEGENDS:

- STUDIO END UNIT
- STUDIO UNIT
- 1 BEDROOM UNIT

BUILDING DETAILS - K

Unit Type	Unit Area (in sqm)	# of Units
I-Bedroom	24.41; 24.99	191
Studio End	23.51	7
Studio	17.63 to 18.21	2
TOTAL		200

- 200 residential units
 - GF – 50 units per floor
 - 2– 4th Floor – 50 units per floor



- LEGENDS:
- STUDIO END UNIT
 - STUDIO UNIT
 - 1 BEDROOM UNIT

Ground Floor

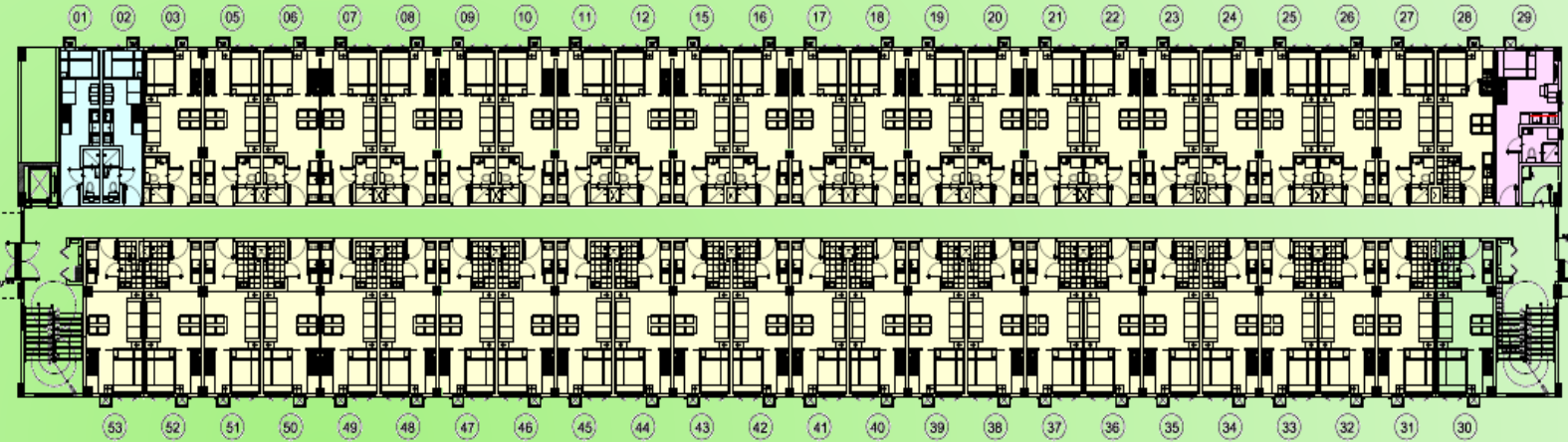

2nd - 4th Floor

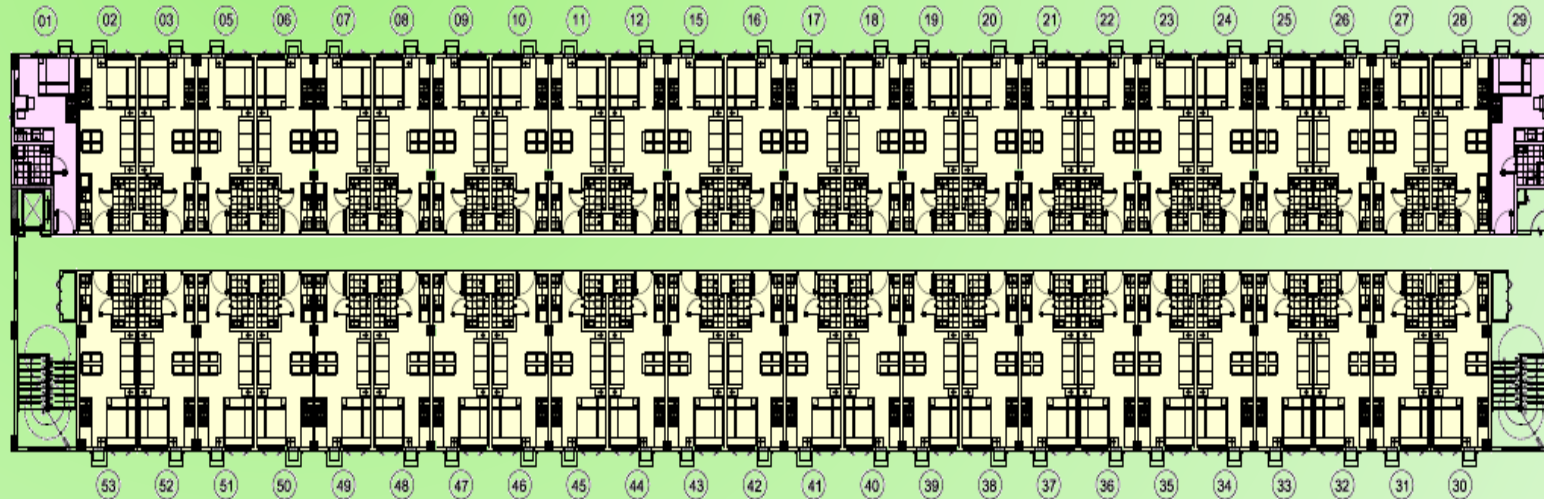

PROJECT FEATURES

- ✓ More than 8,800 sqm allocated for amenities and landscaped areas
- ✓ 24-hour security services
- ✓ Cistern water tanks
- ✓ 1 High speed elevator per Tower
- ✓ 1 Grand lobby at Tower A
- ✓ Back-up power system
- ✓ Fire alarm and sprinkler system
- ✓ Mailroom for each building
- ✓ Centralized garbage collection and disposal system
- ✓ Rain Catchment System for Landscaping
- ✓ LED Lights in common areas
- ✓ Property Management Office
- ✓ Leasing Services



Studio Unit– 17.63sqm

STUDIO UNIT

ROOM DESCRIPTION	FLOOR AREA	
	Square Meters (m ²)	Square Feet (ft ²)
Living/Dining/ Bedroom/Kithen Area	14.31	154.03
Toilet & Bath	3.32	35.74
TOTAL	±17.63	±189.77

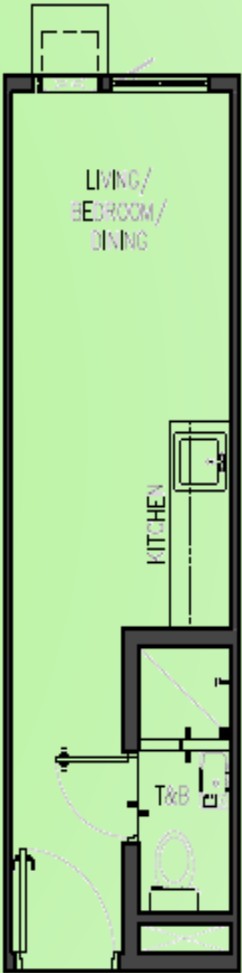
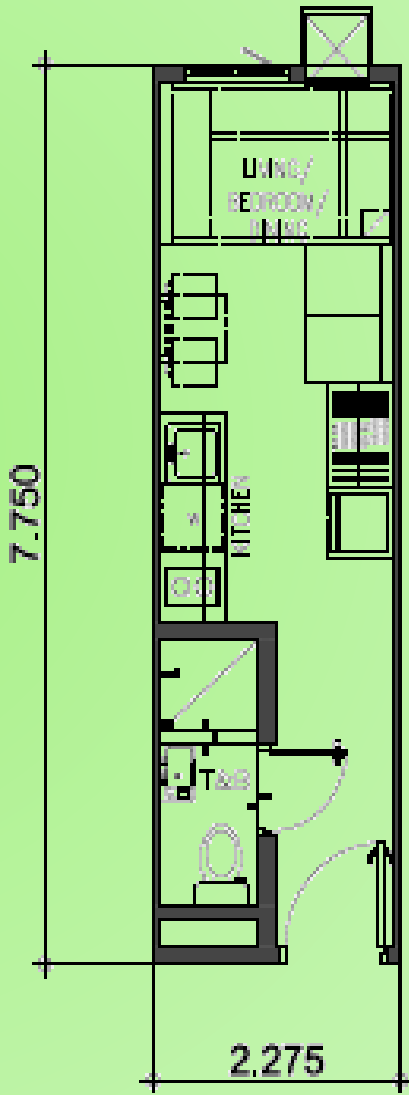

Studio Unit– 18.21sqm

STUDIO UNIT		
ROOM DESCRIPTION	FLOOR AREA	
	Square Meters (m ²)	Square Feet (ft ²)
Living/Dining/ Bedroom/Kitchen Area	14.89	160.27
Toilet & Bath	3.32	35.74
TOTAL	±18.21	±195.95



Studio End Unit– 23.51sqm

STUDIO END UNIT		
ROOM DESCRIPTION	FLOOR AREA	
	Square Meters (m ²)	Square Feet (ft ²)
Living/Dining/Bedroom/Kitchen Area	19.01	204.62
Toilet & Bath	4.50	48.44
TOTAL	±23.51	±253.06

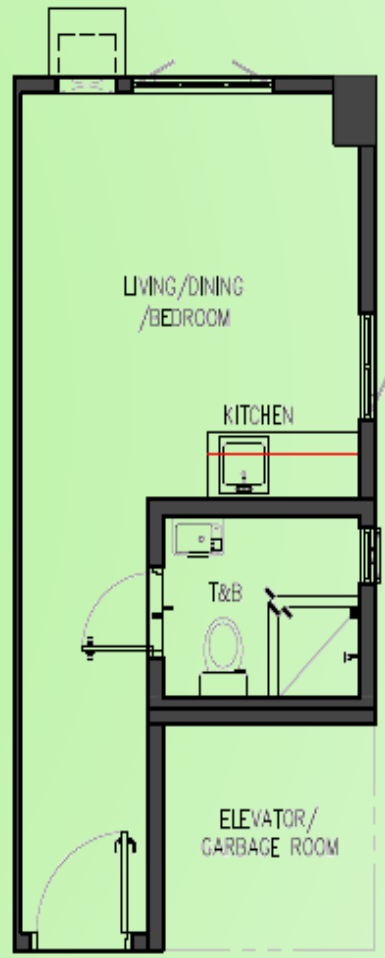
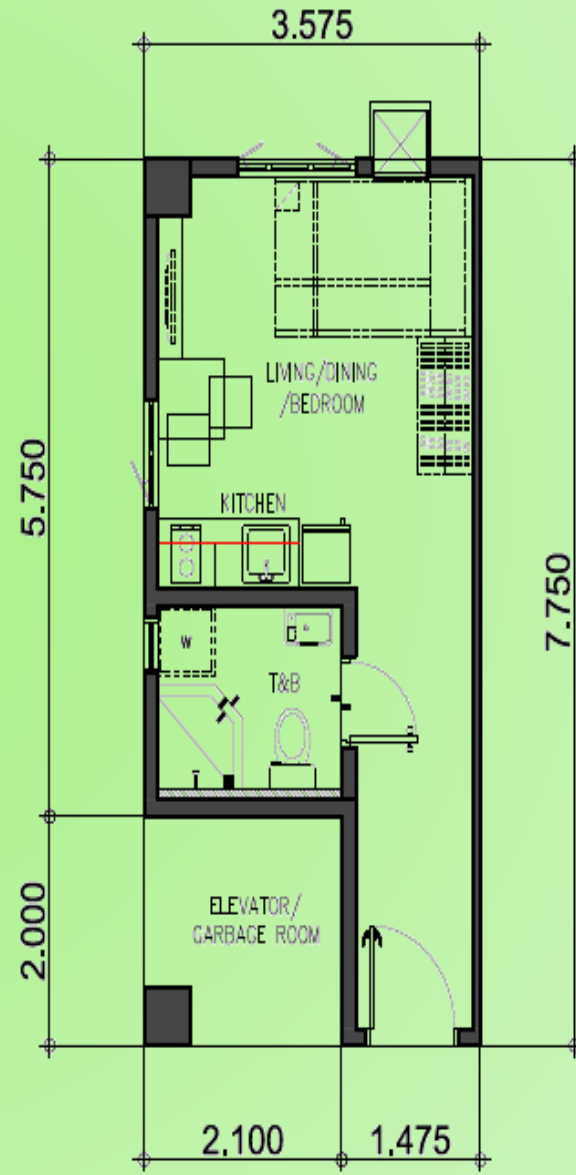

1 Bedroom Unit – 24.41sqm

1 BEDROOM UNIT		
ROOM DESCRIPTION	FLOOR AREA	
	Square Meters (m ²)	Square Feet (ft ²)
Bedroom	7.40	79.65
Living/Dining Area	8.82	94.94
Toilet & Bath	3.58	38.53
Kitchen	4.61	49.62
TOTAL	±24.41	±262.74

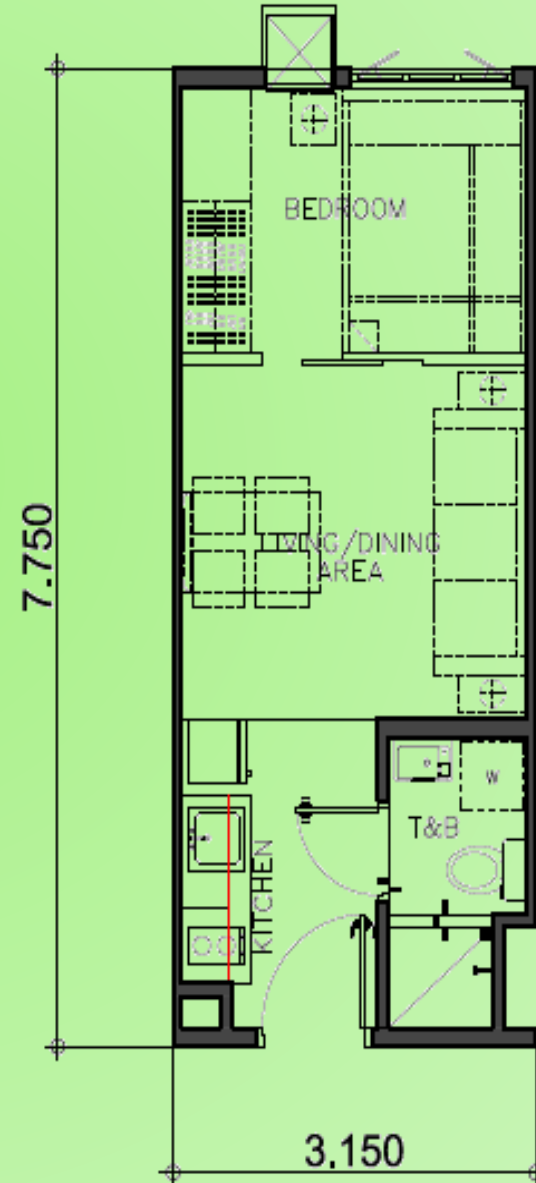

1 Bedroom Unit – 24.99sqm

1 BEDROOM UNIT		
ROOM DESCRIPTION	FLOOR AREA	
	Square Meters (m ²)	Square Feet (ft ²)
Bedroom	7.54	81.16
Living/Dining Area	9.10	97.95
Toilet & Bath	3.58	38.53
Kitchen	4.77	51.34
TOTAL	±24.99	±268.98

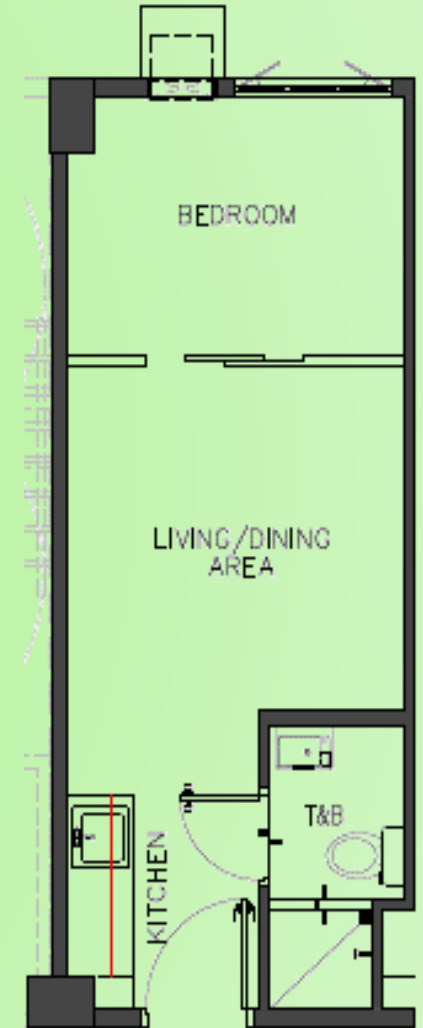
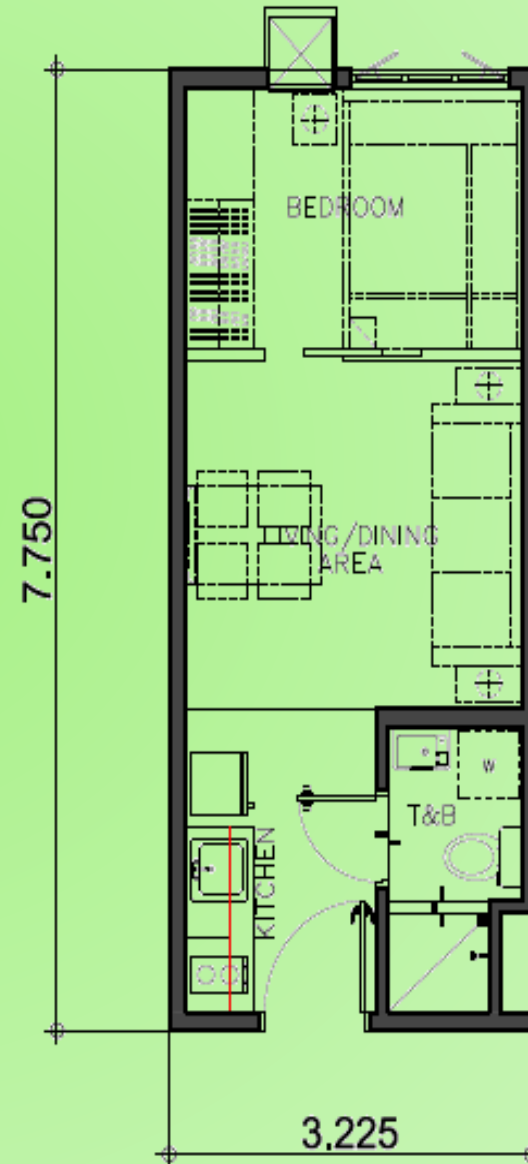

UNIT DELIVERABLES

TYPICAL UNIT FINISHES

WALL FINISH	<p>Bedroom: Semi-gloss paint finish</p> <p>Living/Dining/Kitchen: Semi-gloss paint finish</p> <p>T&B: Semi-gloss paint finish with 1.2m-high tiles on shower area and tiled baseboard</p>
FLOOR FINISH	Ceramic tiles
DOORS	<p>Bedroom: Laminated Wood Door</p> <p>T&B: PVC Door</p> <p>Main: Laminated Wood Door</p>
WINDOWS	Aluminum Casement Window
TOILET & BATH	Water closet, lavatory, soap holder, tissue holder and shower assembly fixtures
KITCHEN	Polished tiles on concrete kitchen countertop

Construction Update:



FREQUENTLY ASKED QUESTIONS:

Who is the owner and developer of GLADE Residences?

SM Development Corporation (SMDC)

What is the ceiling height of the unit?

2.40m - Kitchen and T&B

2.80m - Other Areas

What is the hallway or corridor width?

1.50m

How many elevators are there?

1 per building (8 people capacity)

How many garbage rooms are there?

1 located at the end of each floor of all buildings

What are the utility providers:

Power: MORE Power

Telephone: To be determined

Water: South Balibago Waters, Inc

CATV: To be determined

What are the additional reservation / Leasehold requirements?

Construction Waiver

Where can we accept reservation?

Iloilo City, Bacolod City and Manila

How much is the reservation?

P15,000 – Residential / P10,000 – Parking

What is the unit to parking ratio? -1:6

WHY INVEST IN GLADE RESIDENCES?

**Strategic and
Premium
Location**

**Lush Greeneries
and Outdoor
Spaces**

**Ultimate
Convenience**

**Community Amenities
and Lounges with
Strong WiFi
Connectivity**

**Attainable and
Superior Real Estate
Investment**



THANK YOU AND HAPPY SELLING!

For further inquiries, please contact;

Carl P. Navarro

Assistant Project Development Manager

Email: carl.navarro@smdevelopment.com

For Customer Service Concerns:

Globe – 0917-500-5151

Smart – 0999-991-7632

Email: customerservice@smdevelopment.com