



VAIL

RESIDENCES

CAGAYAN DE ORO CITY

DHSUD PLS No. REM-LS-22-012 (Bldg A to N)
Brgy. Carmen, Cagayan de Oro City
Completion Date: December 2027
Developer: SM Development Corporation

Cagayan de Oro



CAGAYAN DE ORO

Regional Capital and Business Hub of Mindanao

- ✓ **1st Class Highly urbanized City**
- ✓ **Handpicked by the UN as one of the emerging cities**
- ✓ **8th Safest City in Southeast Asia**
- ✓ **Top 5 Most Competitive City (2018)**
- ✓ **Region 10's Tourism Center**
- **Total Population: CDO = 675,950**
- **Number of Barangay – 80**
- **Income Classification – 1st Class**



-  SM MALL
-  SHOPPING CENTER
-  SCHOOL
-  PARK
-  MEDICAL INSTITUTION
-  PLACES OF WORSHIP
-  TRANSPORT TERMINAL

VAIL

RESIDENCES
CAGAYAN DE ORO CITY

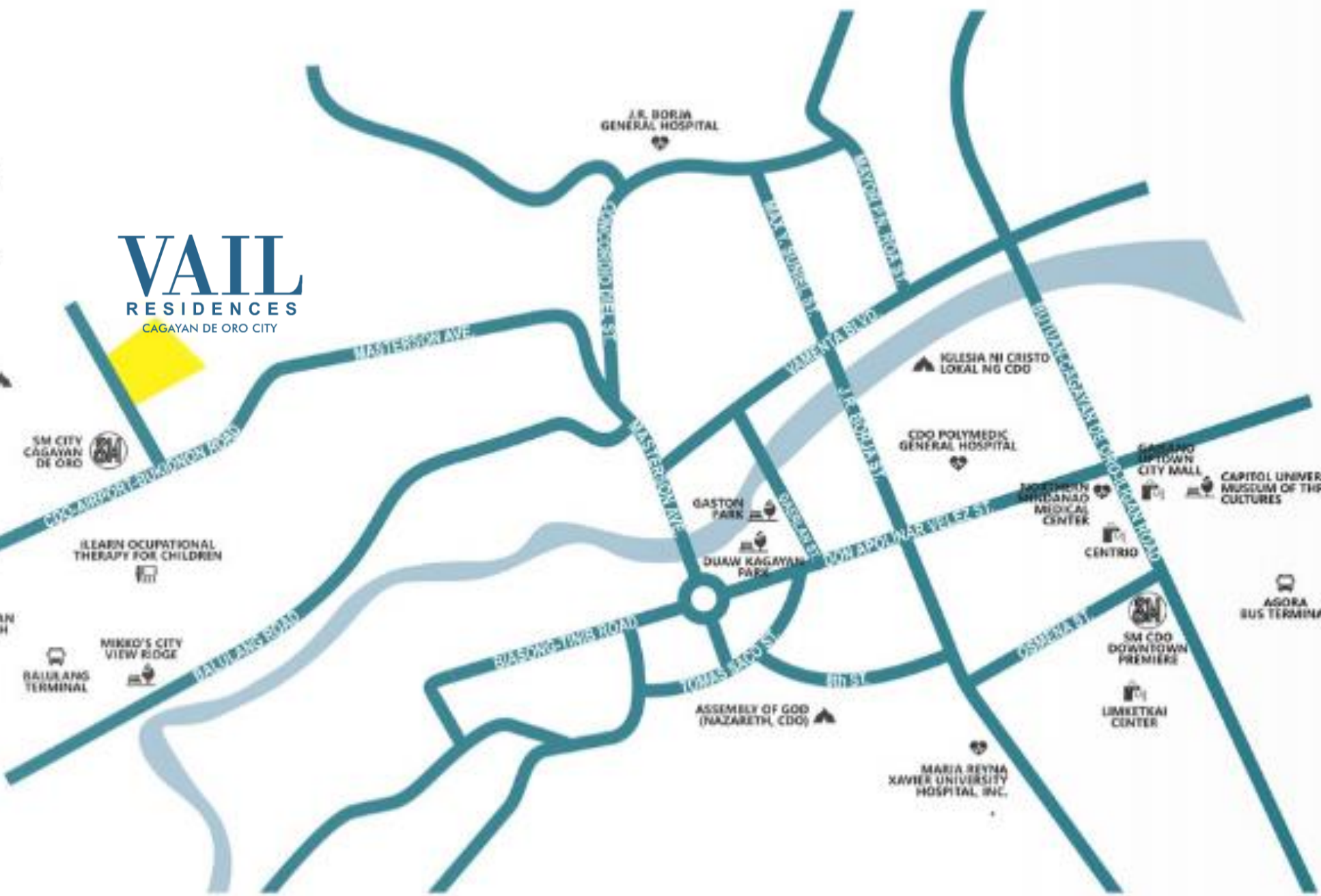

ST. FRANCIS XAVIER PARISH CHURCH

SM CITY CAGAYAN DE ORO

XAVIER UNIVERSITY HIGH SCHOOL

LEARN OCCUPATIONAL THERAPY FOR CHILDREN

CORPUS CRISTI SCHOOL

ST. FRANCIS OR'S MEDICAL CENTER

GREENHILLS CHRISTIAN FELLOWSHIP CHURCH

BALEANG TERMINAL

MIKKO'S CITY VIEW RIDGE

J.R. BORJA GENERAL HOSPITAL

GASTON PARK

DUAW KAGAYAN PARK

ASSEMBLY OF GOD (NAZARETH, CDO)

MARIA REYNA XAVIER UNIVERSITY HOSPITAL, INC.

CDO POLYMEDIC GENERAL HOSPITAL

MODERN MINDANAO MEDICAL CENTER

IGLESIA NI CRISTO LOKAL NG CDO

CENTRO

SM CDO DOWNTOWN PREMIERE

SM CDO DOWNTOWN PREMIERE

UMKETAI CENTER

SM CITY CAGAYAN DE ORO

SM CITY CAGAYAN DE ORO

CAPITOL UNIVERSITY MUSEUM OF THREE CULTURES

AGORA BUS TERMINAL



VAIL

RESIDENCES

CAGAYAN DE ORO CITY

Garden communities that fulfill the aspirations of every Filipino family to live safely, conveniently and comfortably in different progressive areas across the country. This will be the new standard of an upgraded lifestyle by providing sustainable master-planned communities that feature complete facilities and will be professionally managed by a property management company.

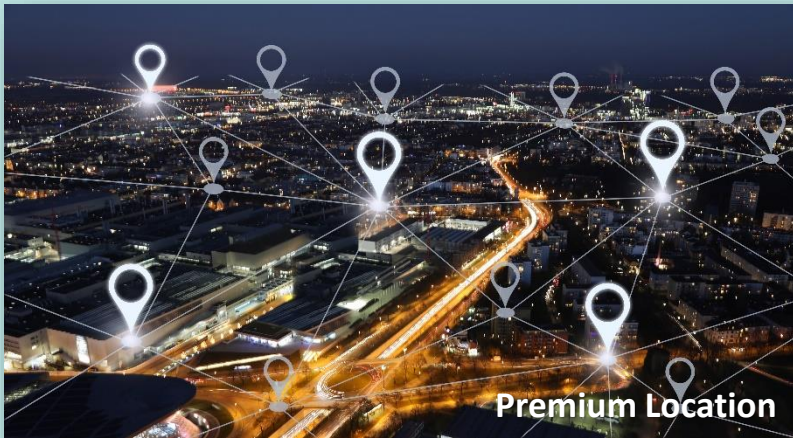

CAGAYAN DE ORO

Places of Interest

Schools and Universities	Distance
Xavier University High School	1.5Km
iLearn Occupational Therapy for Children	1.0Km
Corpus Christi School	1.8Km

Shopping Center/Malls	Distance
SM City Cagayan de Oro Uptown	.30m
Gaisano Uptown City Mall	3.5Km
SM CDO Downtown Premier	6.8Km
Centrio	6.1Km
Limketkai Center	7.0Km

Churches	Distance
St. Francis Xavier Parish Church	1.0Km
Iglesia ni Cristo – Lokal ng CDO	5.1Km
Assembly of God (Nazareth)	5.0Km
Greenhills Christian Fellowship Church	1.0Km



CAGAYAN DE ORO

Places of Interest

Tourist Spots	Distance
Duaw Kagayan Park	4.2Km
Mikko's City View Ridge	7.7Km
Capitol University Museum of Three Cultures	7.3Km
Gaston Park	4.5Km
Amaya View	8 Km

Hospitals	Distance
St. Francis Doctor's Medical Center	1.5Km
JR Borja General Hospital	1.5Km
Cagayan de Oro Polymedic General Hospital	5.5Km
Northern Mindanao Medical Center	1.2Km
Maria Reyna – Xavier University Hospital Inc.	5.9Km

Transport Hubs	Distance
SM Transport Terminal	.30m
Balulang Terminal	1.7Km
Agora Bus Terminal	7.7Km
Bulua Integrated Bus Terminal	8.5Km
Cagayan de Oro Port Terminal Building	8.7Km
Laguindingan Airport	38.5Km



PROJECT DETAILS

Owner/ Developer	SM Development Corporation
Product	MRB 3
Address	PN ROA Sr. Avenue, Brgy. Carmen Uptown Cagayan de Oro City
Gross Land Area	50,003.31sqm
FAR	1.5
No. of Buildings	14; 12 launched bldgs. (B-M)
No. of Residential Units	2,288 Launched units (B-M)
No. of Parking Slots	360 Launched units
Project Launch	April 2022
Completion Date	December 2027
Unit Types	Studio – 17.63 sqm Studio End – 23.51 sqm 1 Bedroom – 24.41 1 Bedroom – 24.99



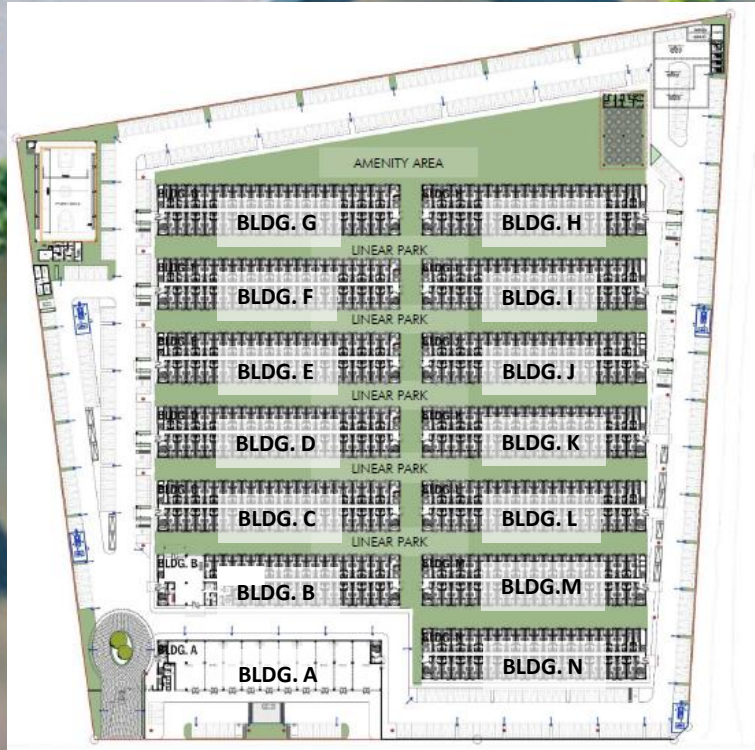

SITE DEVELOPMENT PLAN

GUARDHOUSE – ENTRANCE GATE

VAIL
RESIDENCES
CAGAYAN DE ORO CITY



POOL AND LAWN AREA

VAIL
RESIDENCES
CAGAYAN DE ORO CITY



KIDDIE POOL

VAIL
RESIDENCES
CAGAYAN DE ORO CITY



PAVILION

VAIL
RESIDENCES
CAGAYAN DE ORO CITY



KIDS PLAYGROUND

VAIL
RESIDENCES
CAGAYAN DE ORO CITY



Artist's Perspective

LINEAR PARK

VAIL
RESIDENCES
CAGAYAN DE ORO CITY



Artist's Perspective

GREEN LINK

VAIL
RESIDENCES
CAGAYAN DE ORO CITY



Artist's Perspective

CLUBHOUSE

VAIL
RESIDENCES
CAGAYAN DE ORO CITY



Artist's Perspective

OUTDOOR GYM

VAIL
RESIDENCES
CAGAYAN DE ORO CITY



JOGGING PATH



COVERED BASKETBALL COURT



Artist's Perspective

GRAND LOBBY



STUDIO UNIT – 17.63 SQM

VAIL
RESIDENCES
CAGAYAN DE ORO CITY



1 BEDROOM UNIT – 24.41 SQM



BUILDING CHART



PHASE 1 – BUILDINGS B,C,D & E

BUILDING	NO. OF UNITS
B	188
C	199
D	200
E	199
TOTAL	786

Unit Breakdown:

- Buildings F, G, H – 584 units
- Buildings I, J, K, L – 735 units
- Buildings M, N, & A – 505 units

No. of Units per Type (Phase 1)

- Studio - 2
- Studio End - 28
- 1 BR - 756

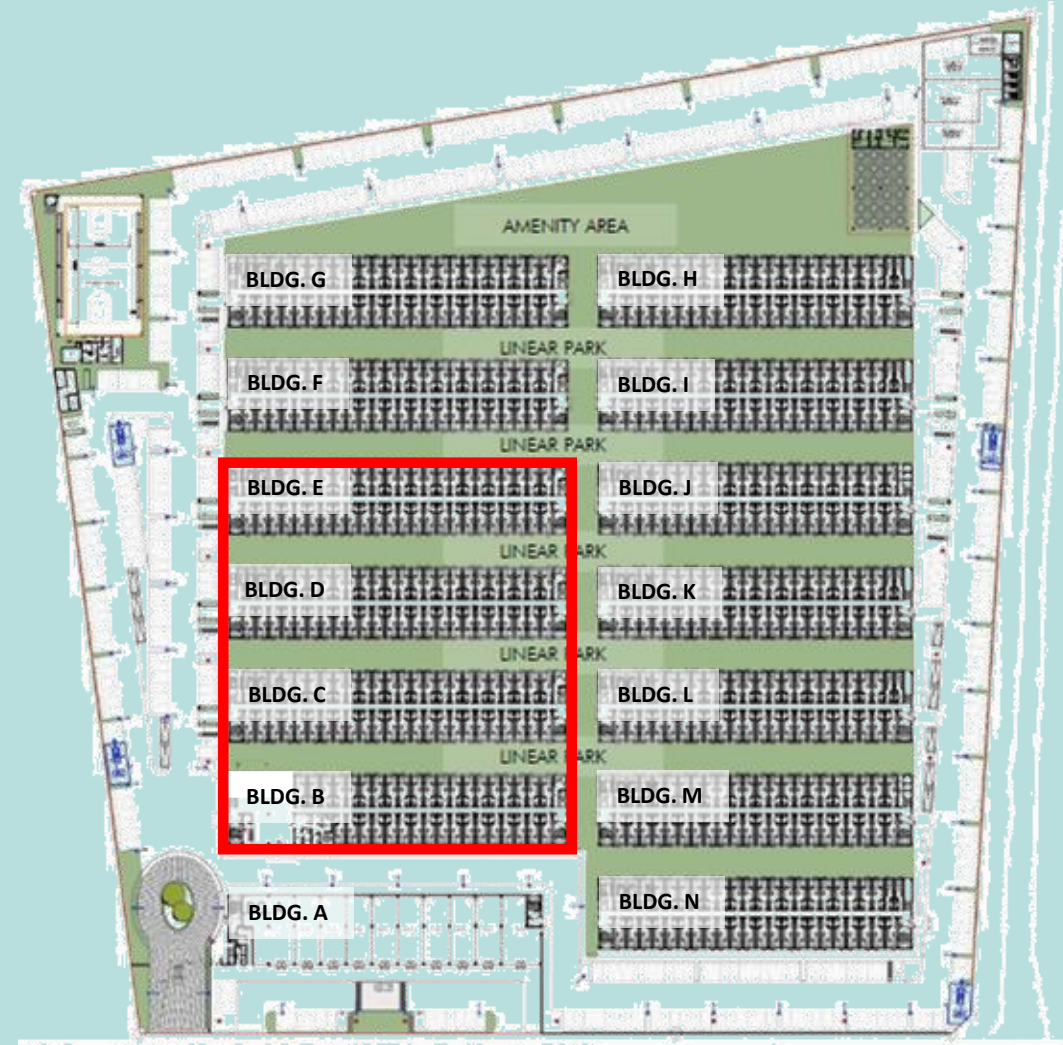

BUILDING DETAILS - B

UNIT TYPE	AREA (in sqm)	UNIT COUNT
Studio	17.63-18.21	-
Studio End	23.51	7
1 Bedroom	24.41	172
1 Bedroom	24.99	8
1 Bedroom	25.96	1
TOTAL		188

Unit Breakdown:

- Ground Floor – 38 units
- 2nd-4th Floor – 50 units /level

GROUND FLOOR

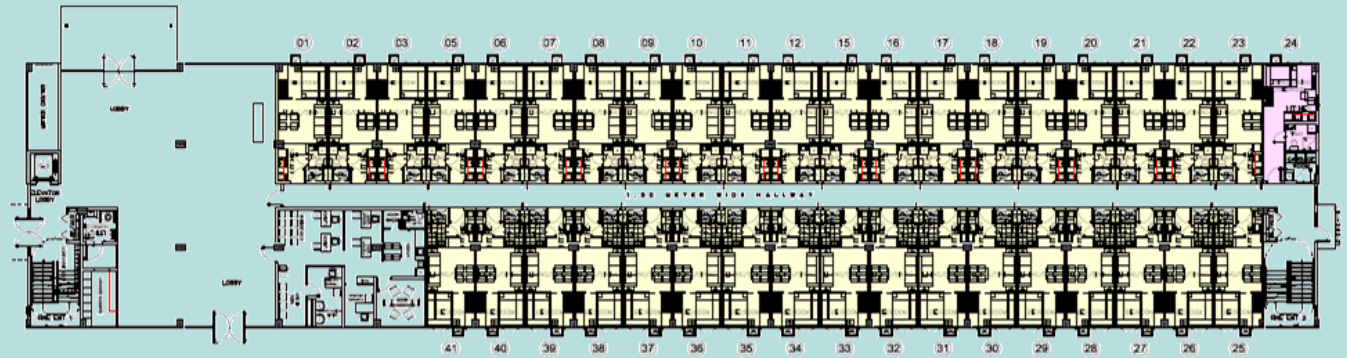

2nd to 4th FLOOR

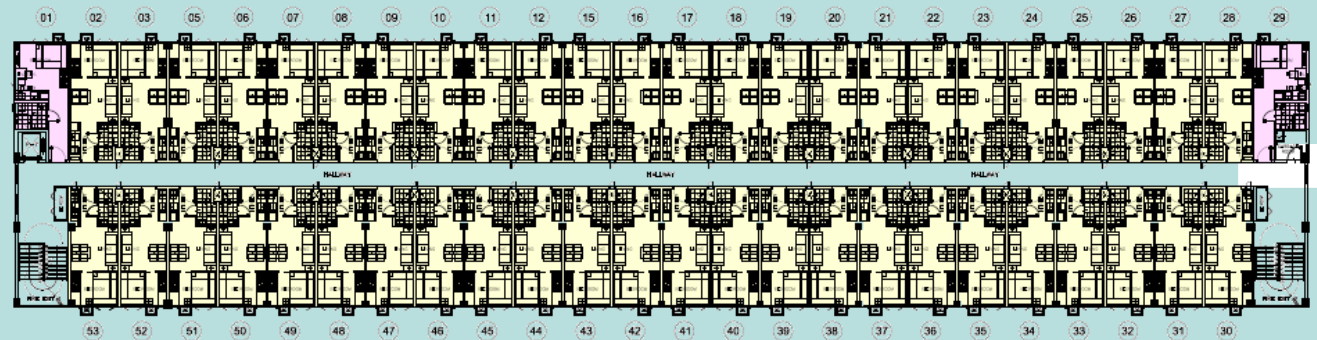

KEY PLAN

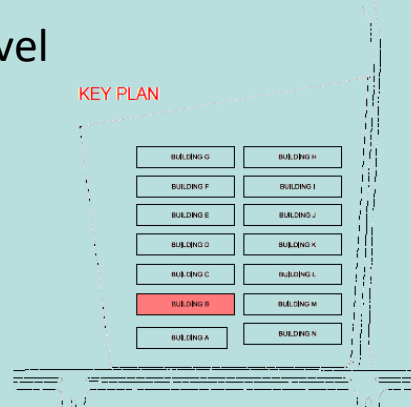

LEGENDS:

- STUDIO END UNIT
- 1 BEDROOM UNIT



BUILDING DETAILS - C

UNIT TYPE	AREA (in sqm)	UNIT COUNT
Studio	17.63-18.21	-
Studio End	23.51	7
1 Bedroom	24.41	183
1 Bedroom	24.99	9
1 Bedroom	25.96	-
TOTAL		199

Unit Breakdown:

- Ground Floor – 49 units
- 2nd-4th Floor – 50 units /level

GROUND FLOOR

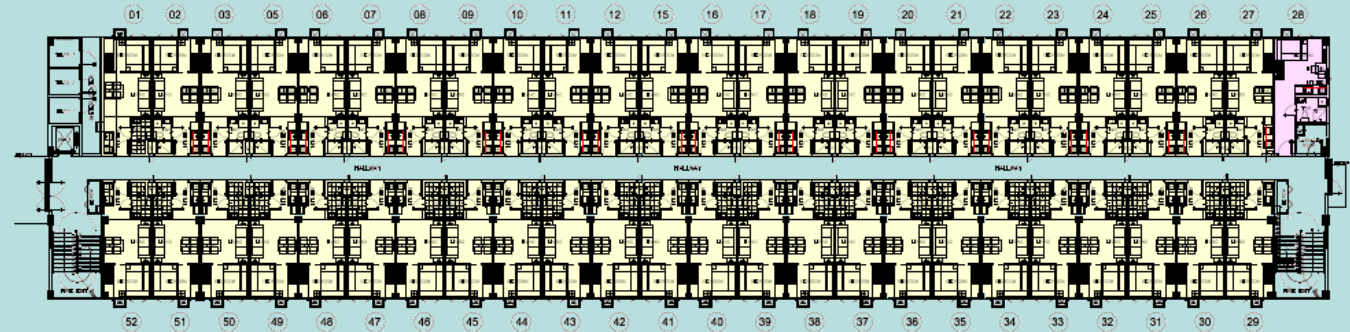

2nd to 4th FLOOR

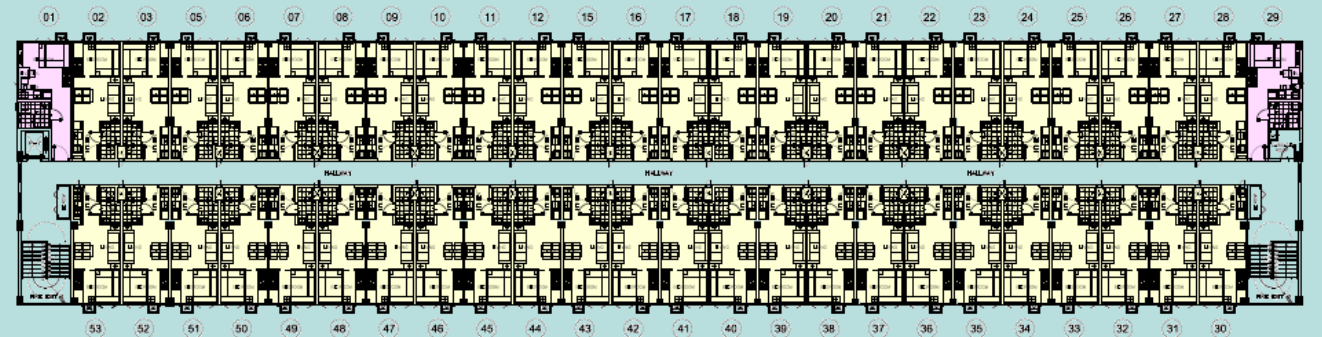

KEY PLAN

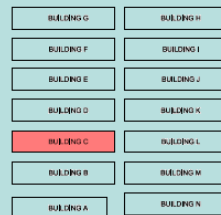

LEGENDS:

- STUDIO END UNIT
- 1 BEDROOM UNIT



BUILDING DETAILS - D

UNIT TYPE	AREA (in sqm)	UNIT COUNT
Studio	17.63-18.21	2
Studio End	23.51	7
1 Bedroom	24.41	183
1 Bedroom	24.99	8
1 Bedroom	25.96	-
TOTAL		200

Unit Breakdown:

- Ground Floor – 50 units
- 2nd-4th Floor – 50 units /level

KEY PLAN

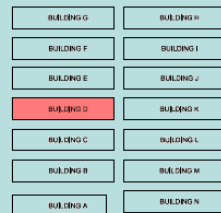

GROUND FLOOR

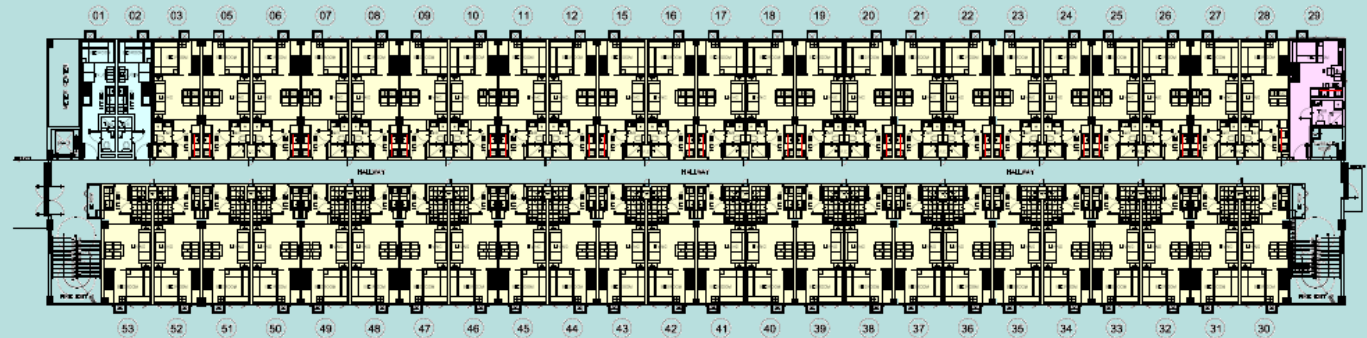

2nd to 4th FLOOR

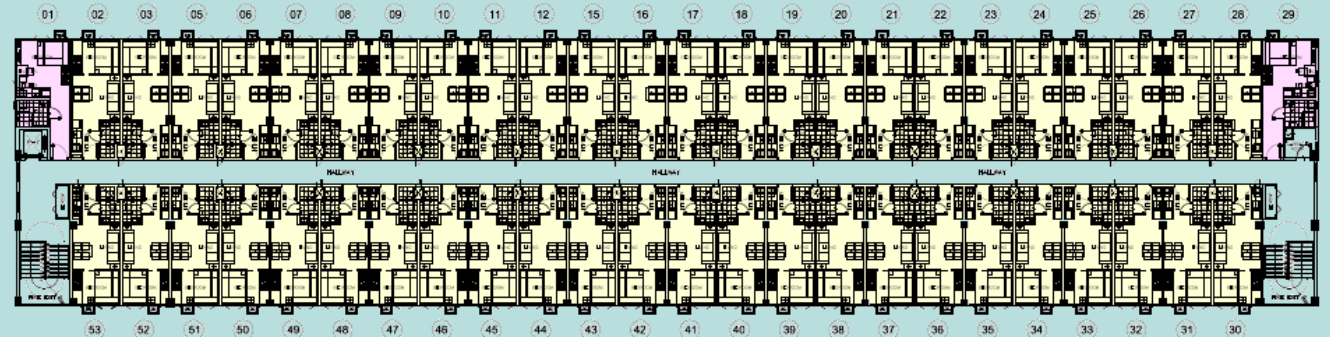

LEGENDS:

- STUDIO END UNIT
- 1 BEDROOM UNIT



BUILDING DETAILS - E

UNIT TYPE	AREA (in sqm)	UNIT COUNT
Studio	17.63-18.21	-
Studio End	23.51	7
1 Bedroom	24.41	183
1 Bedroom	24.99	9
1 Bedroom	25.96	-
TOTAL		199

Unit Breakdown:

- Ground Floor – 49 units
- 2nd-4th Floor – 50 units /level

KEY PLAN

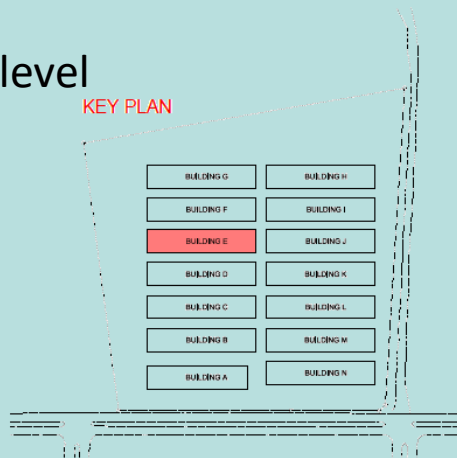

GROUND FLOOR

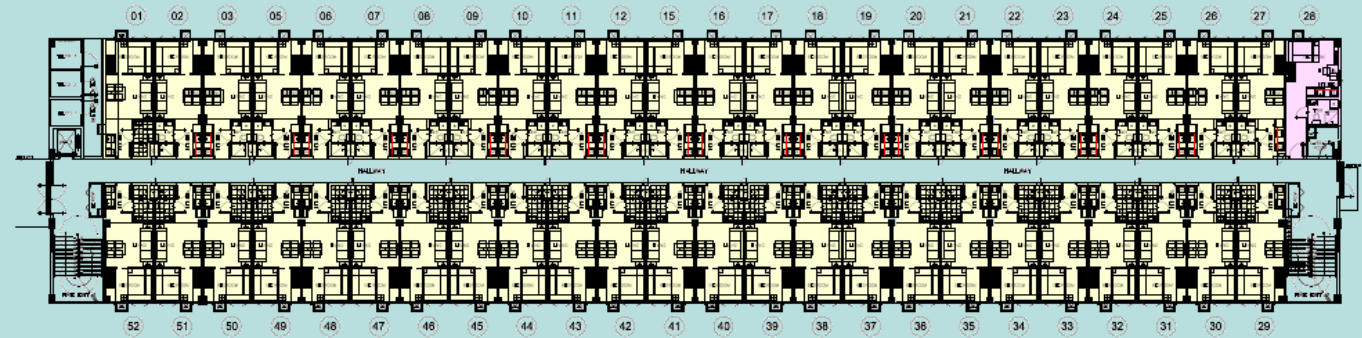

2nd to 4th FLOOR

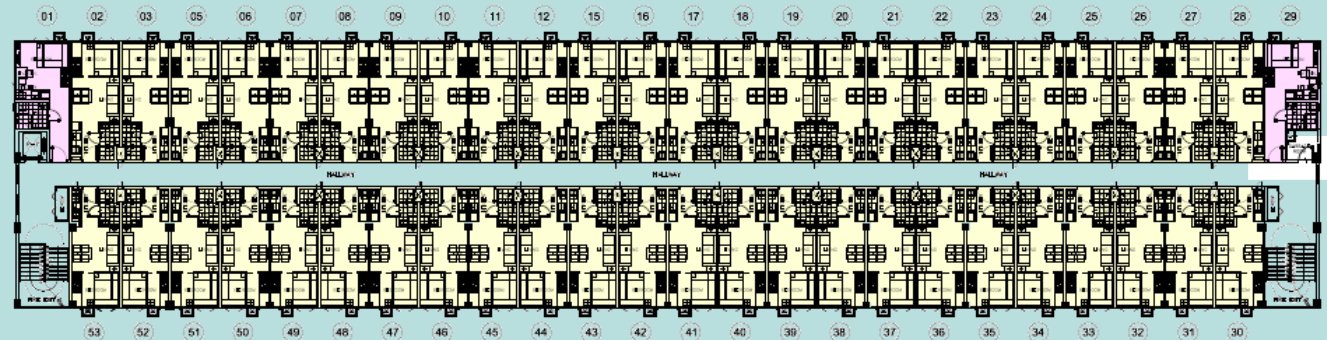

LEGENDS:

- STUDIO END UNIT
- 1 BEDROOM UNIT



BUILDING DETAILS - F

UNIT TYPE	AREA (in sqm)	UNIT COUNT
Studio	17.63-18.21	2
Studio End	23.51	7
1 Bedroom	24.41	183
1 Bedroom	24.99	8
1 Bedroom	25.96	-
TOTAL		200

Unit Breakdown:

- Ground Floor – 50 units
- 2nd-4th Floor – 50 units /level

GROUND FLOOR

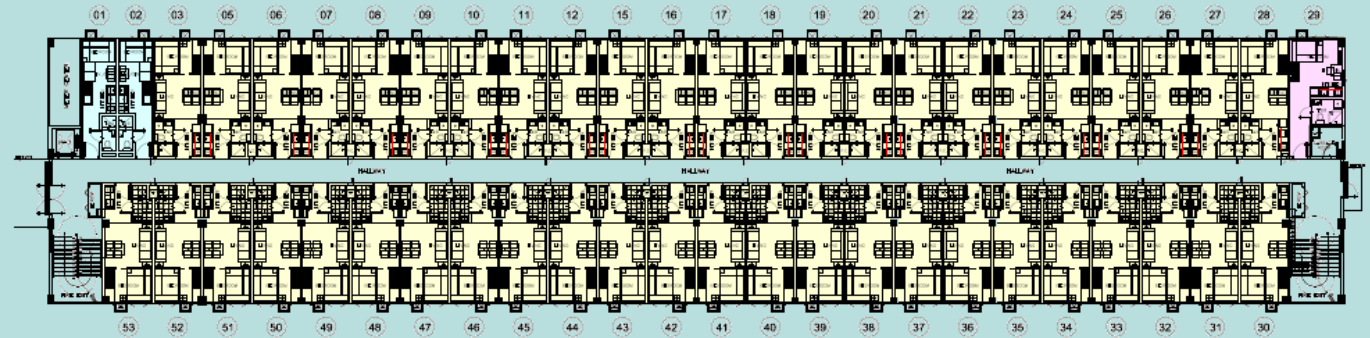

2nd to 4th FLOOR

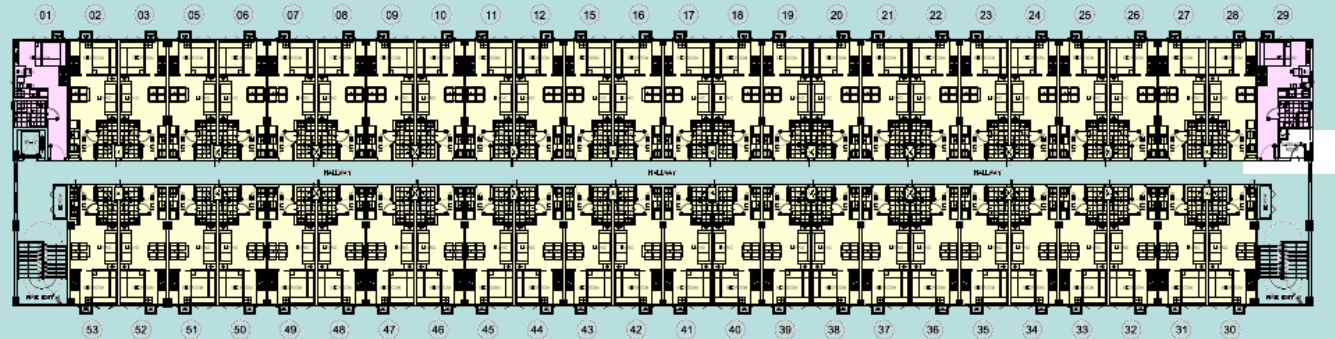

KEY PLAN

BUILDING G	BUILDING H
BUILDING F	BUILDING I
BUILDING E	BUILDING J
BUILDING D	BUILDING K
BUILDING C	BUILDING L
BUILDING B	BUILDING M
BUILDING A	BUILDING N

LEGENDS:

- STUDIO END UNIT
- 1 BEDROOM UNIT



BUILDING DETAILS - G

UNIT TYPE	AREA (in sqm)	UNIT COUNT
Studio	17.63-18.21	2
Studio End	23.51	7
1 Bedroom	24.41	183
1 Bedroom	24.99	8
1 Bedroom	25.96	-
TOTAL		200

Unit Breakdown:

- Ground Floor – 50 units
- 2nd-4th Floor – 50 units /level

GROUND FLOOR

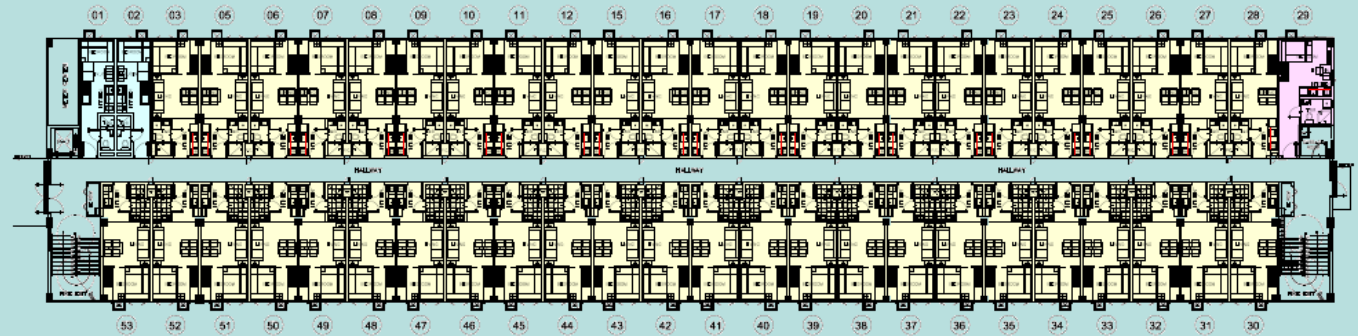

2nd to 4th FLOOR

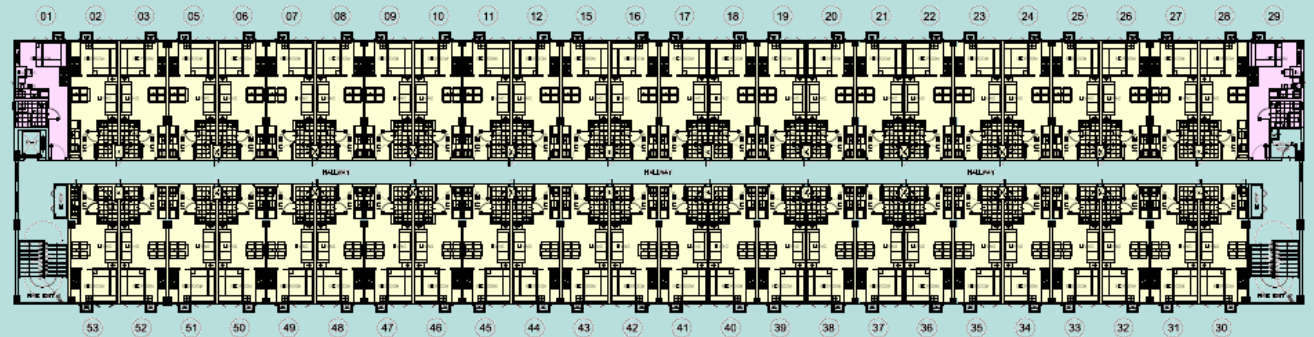

KEY PLAN

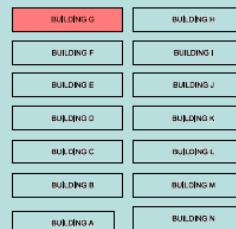

LEGENDS:

- STUDIO END UNIT
- 1 BEDROOM UNIT



BUILDING DETAILS - H

UNIT TYPE	AREA (in sqm)	UNIT COUNT
Studio	17.63-18.21	2
Studio End	23.51	7
1 Bedroom	24.41	167
1 Bedroom	24.99	8
1 Bedroom	25.96	-
TOTAL		184

Unit Breakdown:

- Ground Floor – 46 units
- 2nd-4th Floor – 46 units /level

GROUND FLOOR

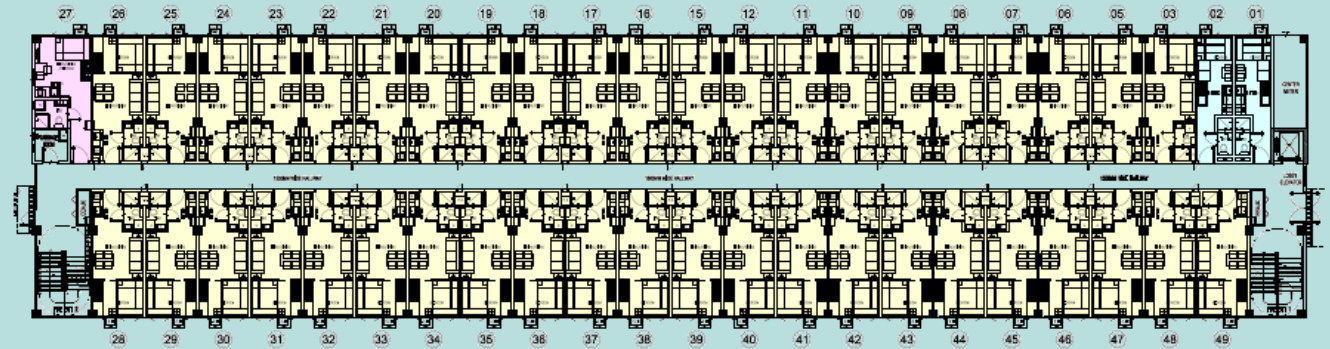

2nd to 4th FLOOR

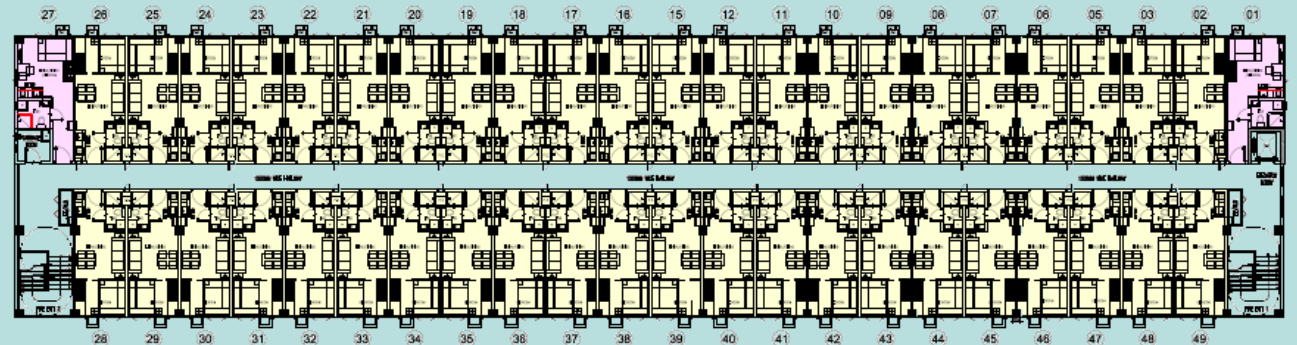

KEY PLAN

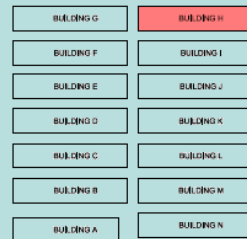

LEGENDS:

- STUDIO END UNIT
- 1 BEDROOM UNIT



BUILDING DETAILS - I

UNIT TYPE	AREA (in sqm)	UNIT COUNT
Studio	17.63-18.21	2
Studio End	23.51	7
1 Bedroom	24.41	167
1 Bedroom	24.99	8
1 Bedroom	25.96	-
TOTAL		184

Unit Breakdown:

- Ground Floor – 46 units
- 2nd-4th Floor – 46 units /level

GROUND FLOOR

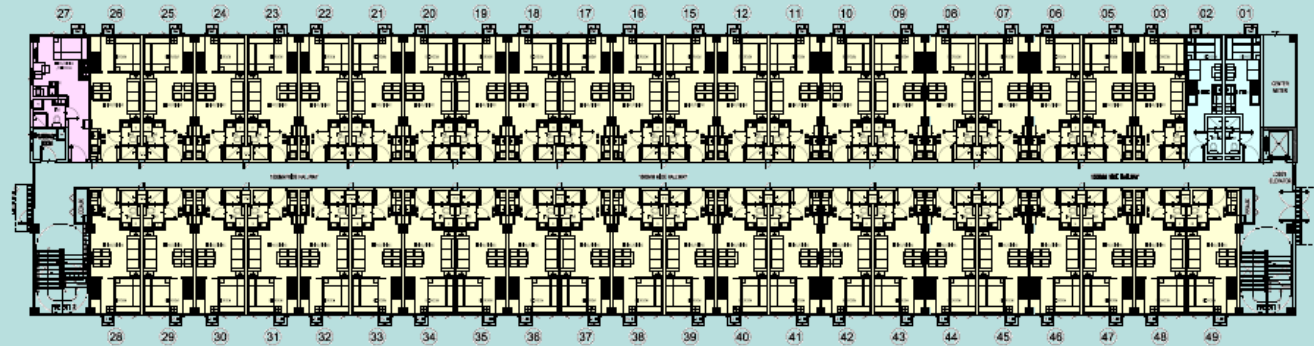

2nd to 4th FLOOR

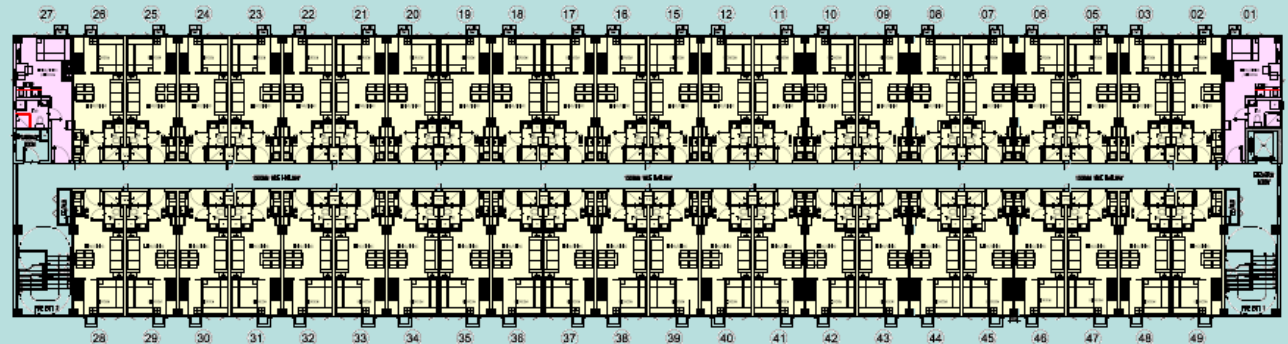

KEY PLAN

BUILDING G	BUILDING H
BUILDING F	BUILDING I
BUILDING E	BUILDING J
BUILDING D	BUILDING K
BUILDING C	BUILDING L
BUILDING B	BUILDING M
BUILDING A	BUILDING N

LEGENDS:

- STUDIO END UNIT
- 1 BEDROOM UNIT



BUILDING DETAILS - J

UNIT TYPE	AREA (in sqm)	UNIT COUNT
Studio	17.63-18.21	-
Studio End	23.51	7
1 Bedroom	24.41	167
1 Bedroom	24.99	9
1 Bedroom	25.96	-
TOTAL		183

Unit Breakdown:

- Ground Floor – 45 units
- 2nd-4th Floor – 46 units /level

GROUND FLOOR

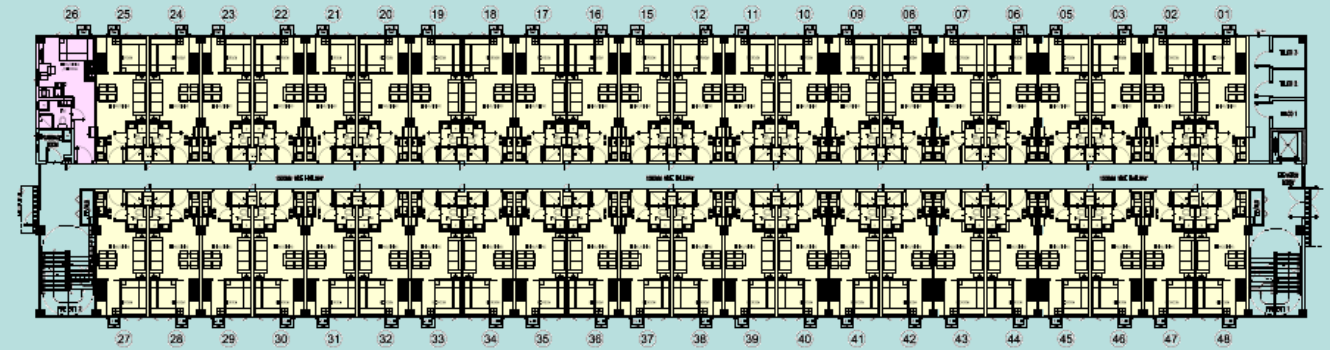

2nd to 4th FLOOR

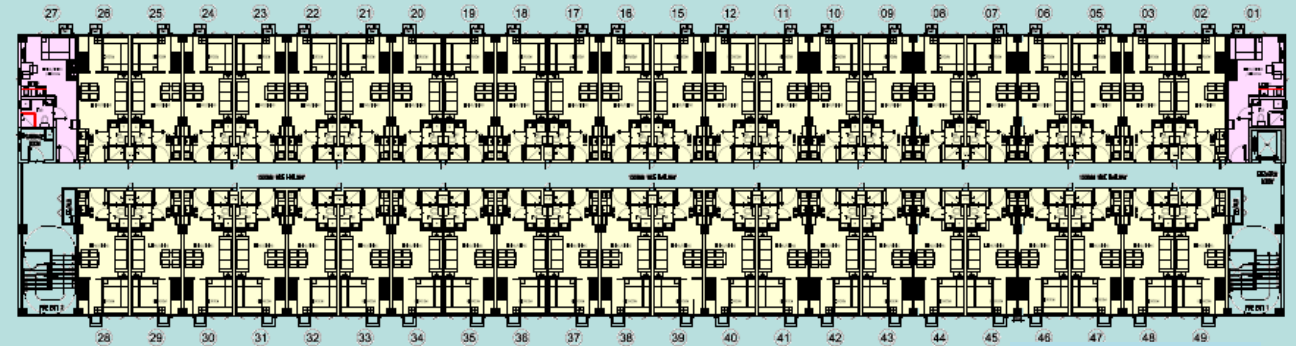

KEY PLAN

BUILDING G	BUILDING M
BUILDING F	BUILDING I
BUILDING E	BUILDING J
BUILDING D	BUILDING K
BUILDING C	BUILDING L
BUILDING B	BUILDING N
BUILDING A	BUILDING O

LEGENDS:

- STUDIO END UNIT
- 1 BEDROOM UNIT



BUILDING DETAILS - K

UNIT TYPE	AREA (in sqm)	UNIT COUNT
Studio	17.63-18.21	2
Studio End	23.51	7
1 Bedroom	24.41	167
1 Bedroom	24.99	8
1 Bedroom	25.96	-
TOTAL		184

Unit Breakdown:

- Ground Floor – 46 units
- 2nd-4th Floor – 46 units /level

GROUND FLOOR

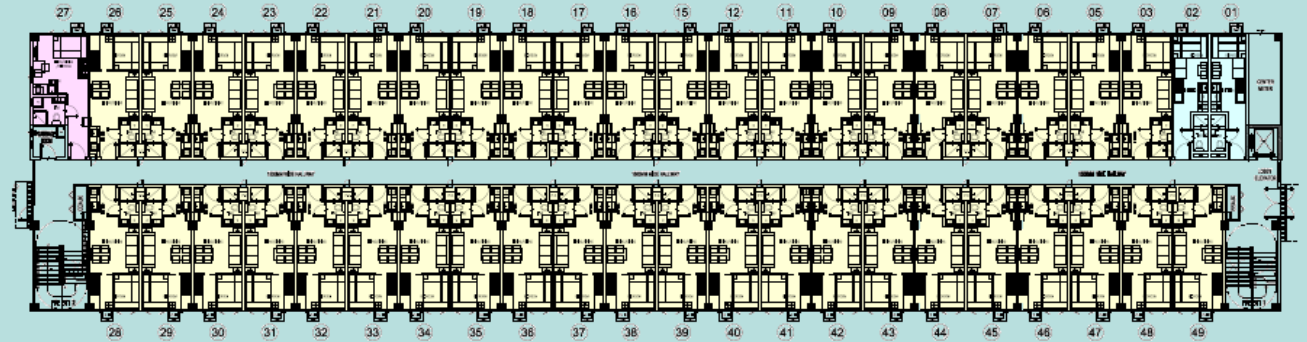

2nd to 4th FLOOR

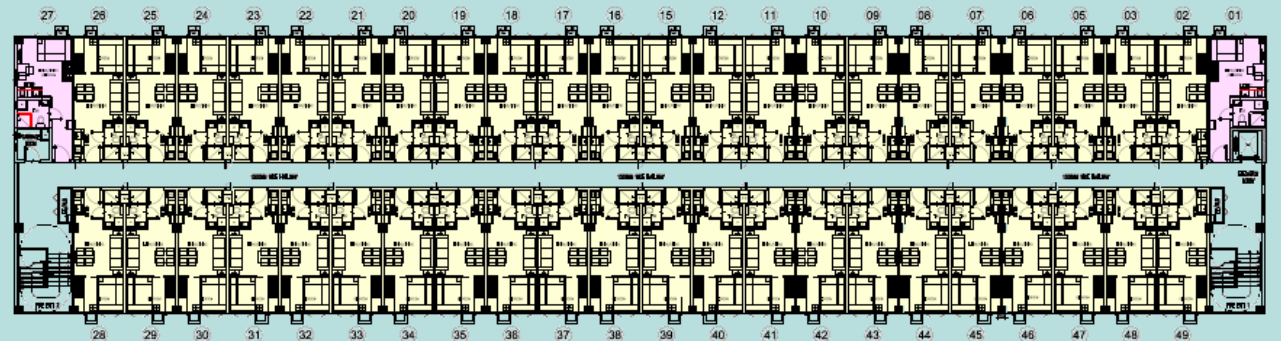

KEY PLAN

BUILDING G	BUILDING H
BUILDING F	BUILDING I
BUILDING E	BUILDING J
BUILDING D	BUILDING K
BUILDING C	BUILDING L
BUILDING B	BUILDING M
BUILDING A	BUILDING N

LEGENDS:

- STUDIO END UNIT
- 1 BEDROOM UNIT



BUILDING DETAILS - L

UNIT TYPE	AREA (in sqm)	UNIT COUNT
Studio	17.63-18.21	2
Studio End	23.51	7
1 Bedroom	24.41	167
1 Bedroom	24.99	8
1 Bedroom	25.96	-
TOTAL		184

Unit Breakdown:

- Ground Floor – 46 units
- 2nd-4th Floor – 46 units /level

GROUND FLOOR

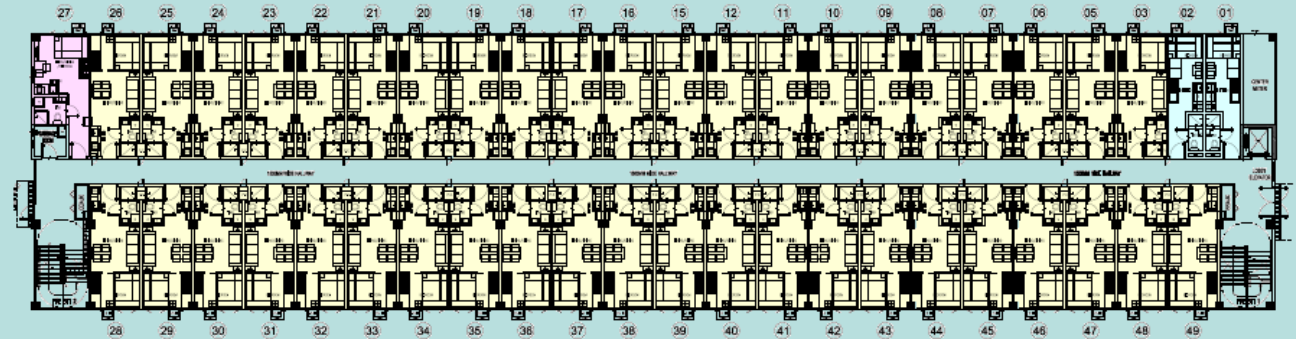

2nd to 4th FLOOR

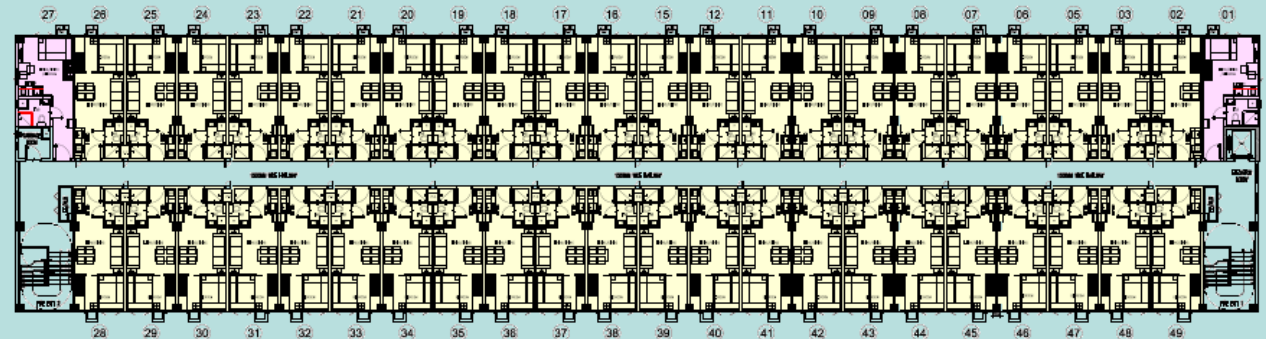

KEY PLAN

BUILDING G	BUILDING H
BUILDING F	BUILDING I
BUILDING E	BUILDING J
BUILDING D	BUILDING K
BUILDING C	BUILDING L
BUILDING B	BUILDING M
BUILDING A	BUILDING N

LEGENDS:

- STUDIO END UNIT
- 1 BEDROOM UNIT



BUILDING DETAILS - M

UNIT TYPE	AREA (in sqm)	UNIT COUNT
Studio	17.63-18.21	-
Studio End	23.51	7
1 Bedroom	24.41	167
1 Bedroom	24.99	9
1 Bedroom	25.96	-
TOTAL		183

Unit Breakdown:

- Ground Floor – 45 units
- 2nd-4th Floor – 46 units /level

GROUND FLOOR

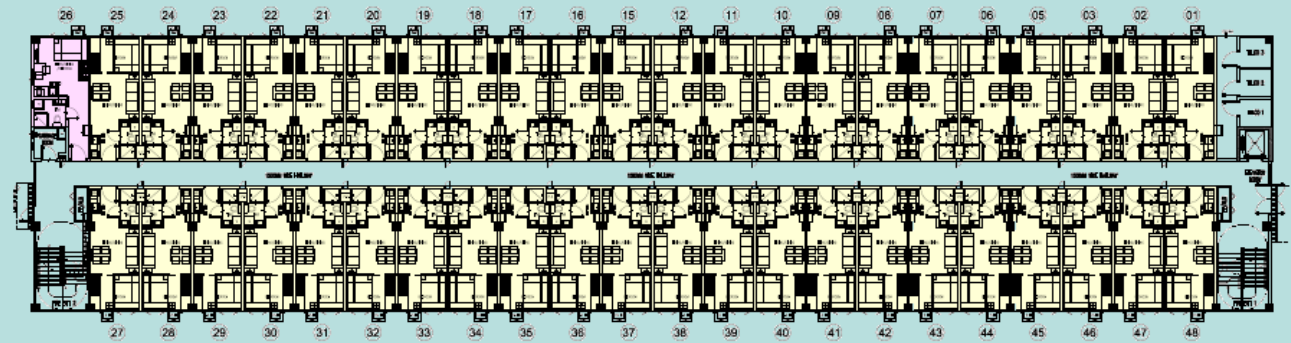

2nd to 4th FLOOR

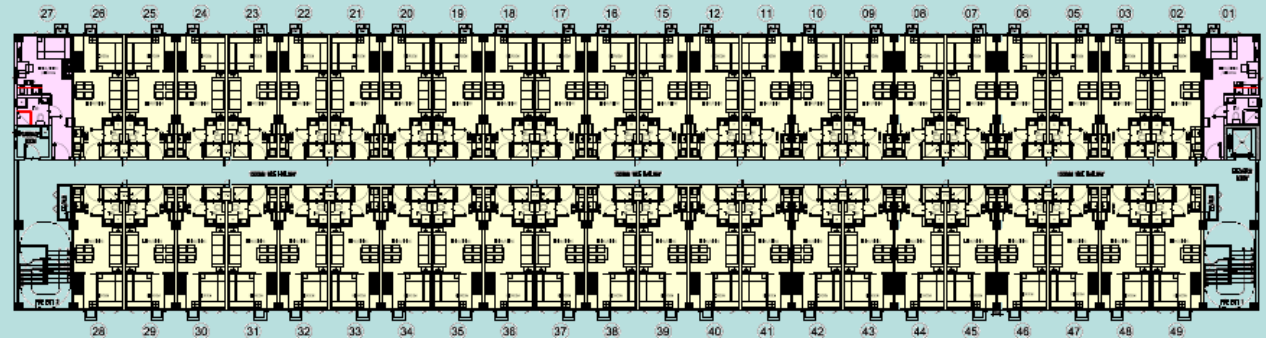

KEY PLAN

BUILDING G	BUILDING H
BUILDING F	BUILDING I
BUILDING E	BUILDING J
BUILDING D	BUILDING K
BUILDING C	BUILDING L
BUILDING B	BUILDING M
BUILDING A	BUILDING N

LEGENDS:

- STUDIO END UNIT
- 1 BEDROOM UNIT

STUDIO – 17.63 SQM

STUDIO UNIT		
ROOM DESCRIPTION	FLOOR AREA	
	Square Meters (m ²)	Square Feet (ft ²)
Living/Dining/ Bedroom/Kitchen Area	14.31	154.03
Toilet & Bath	3.32	35.74
TOTAL	±17.63	±189.77

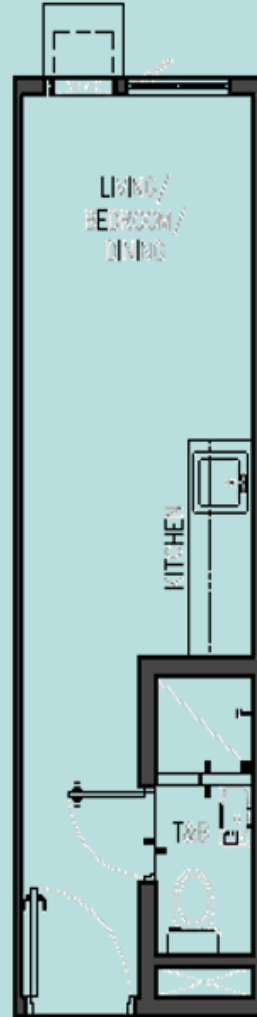
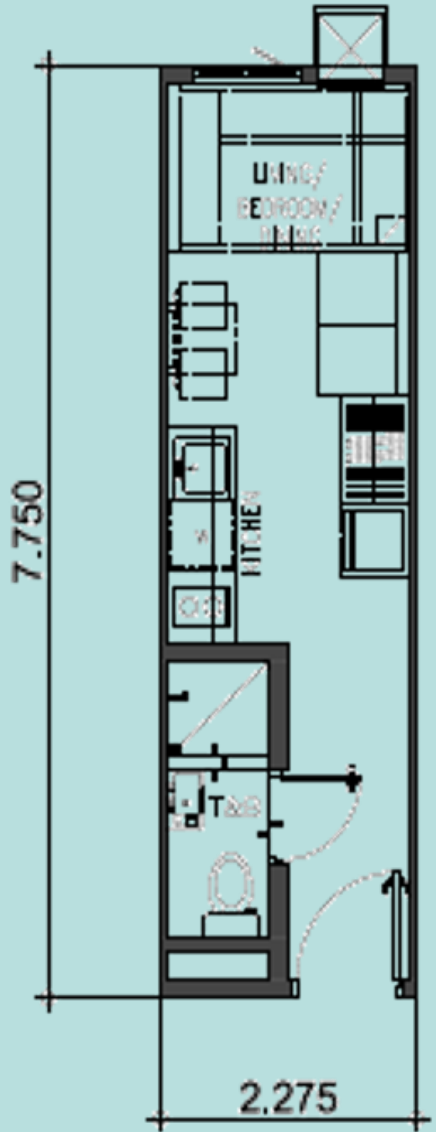

STUDIO – 18.21 SQM

STUDIO UNIT		
ROOM DESCRIPTION	FLOOR AREA	
	Square Meters (m ²)	Square Feet (ft ²)
Living/Dining/ Bedroom/Kitchen Area	14.89	160.27
Toilet & Bath	3.32	35.74
TOTAL	±18.21	±195.95



STUDIO END— 23.51 SQM

STUDIO END UNIT		
ROOM DESCRIPTION	FLOOR AREA	
	Square Meters (m ²)	Square Feet (ft ²)
Living/Dining/Bedroom/Kitchen Area	19.01	204.62
Toilet & Bath	4.50	48.44
TOTAL	±23.51	±253.06

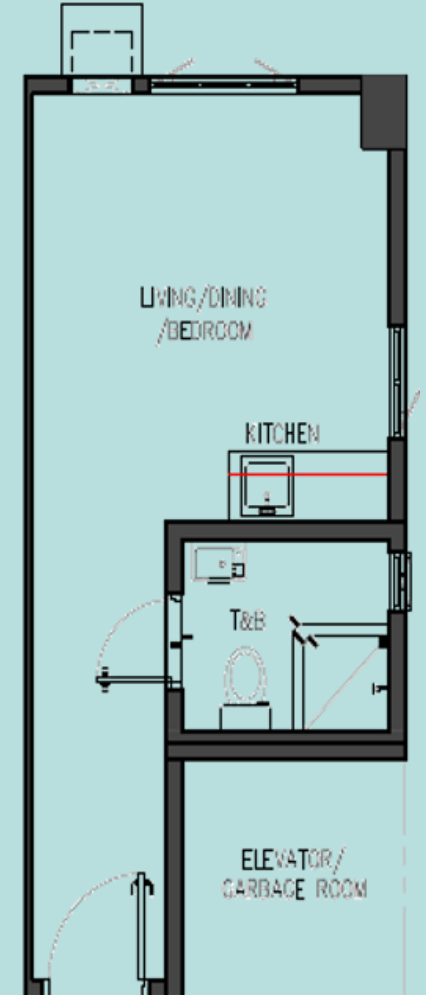
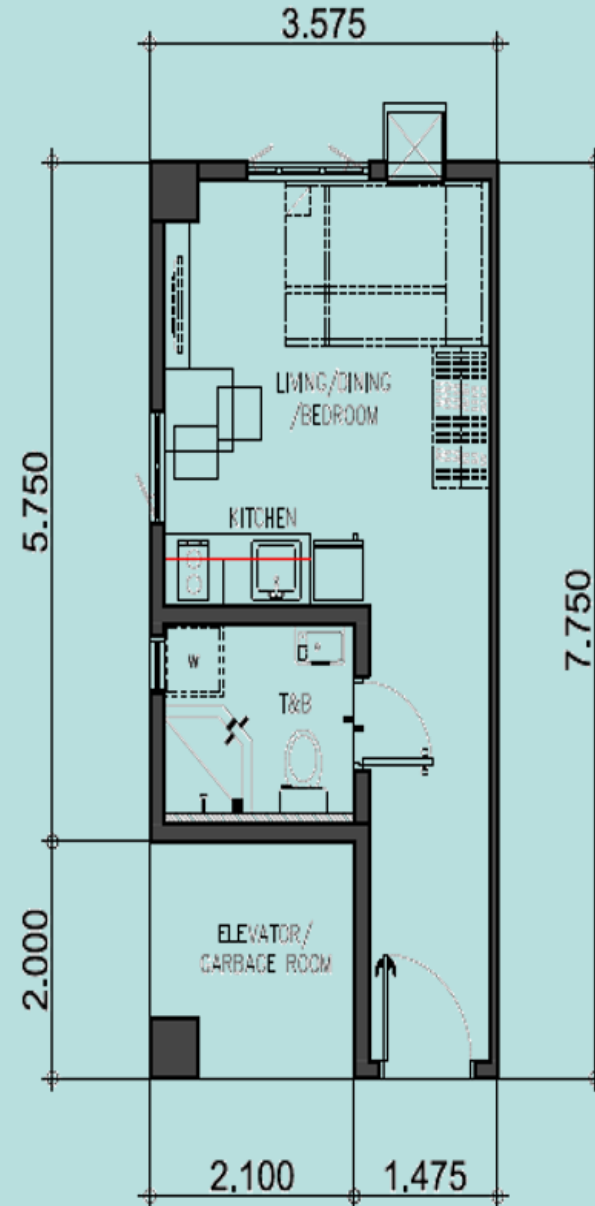

1 BEDROOM – 24.41 SQM

1 BEDROOM UNIT

ROOM DESCRIPTION	FLOOR AREA	
	Square Meters (m ²)	Square Feet (ft ²)
Bedroom	7.40	79.65
Living/Dining Area	8.82	94.94
Toilet & Bath	3.58	38.53
Kitchen	4.61	49.62
TOTAL	±24.41	±262.74

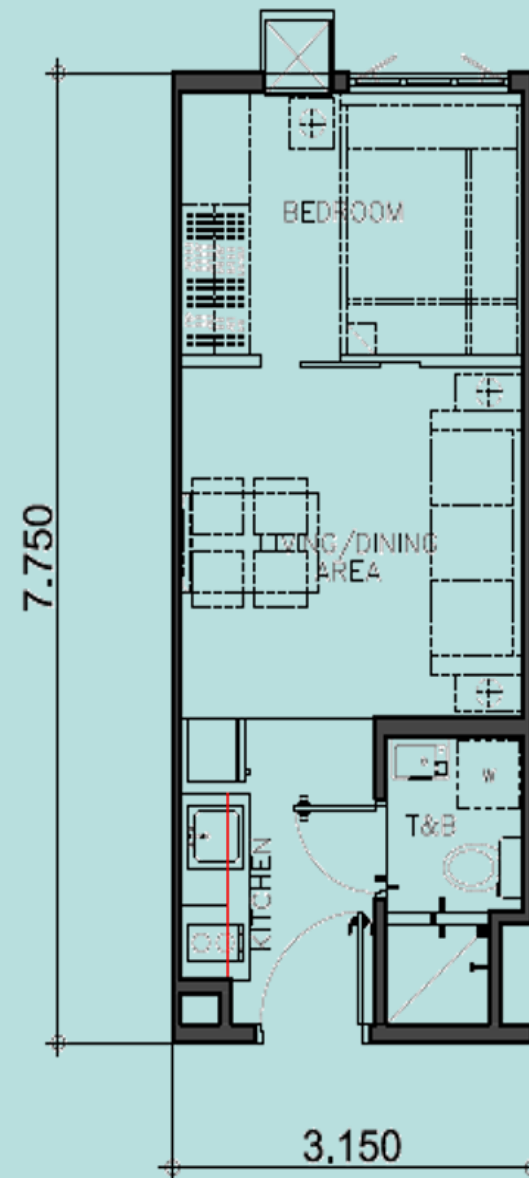

1 BEDROOM – 24.99 SQM

1 BEDROOM UNIT

ROOM DESCRIPTION	FLOOR AREA	
	Square Meters (m ²)	Square Feet (ft ²)
Bedroom	7.54	81.16
Living/Dining Area	9.10	97.95
Toilet & Bath	3.58	38.53
Kitchen	4.77	51.34
TOTAL	±24.99	±268.98

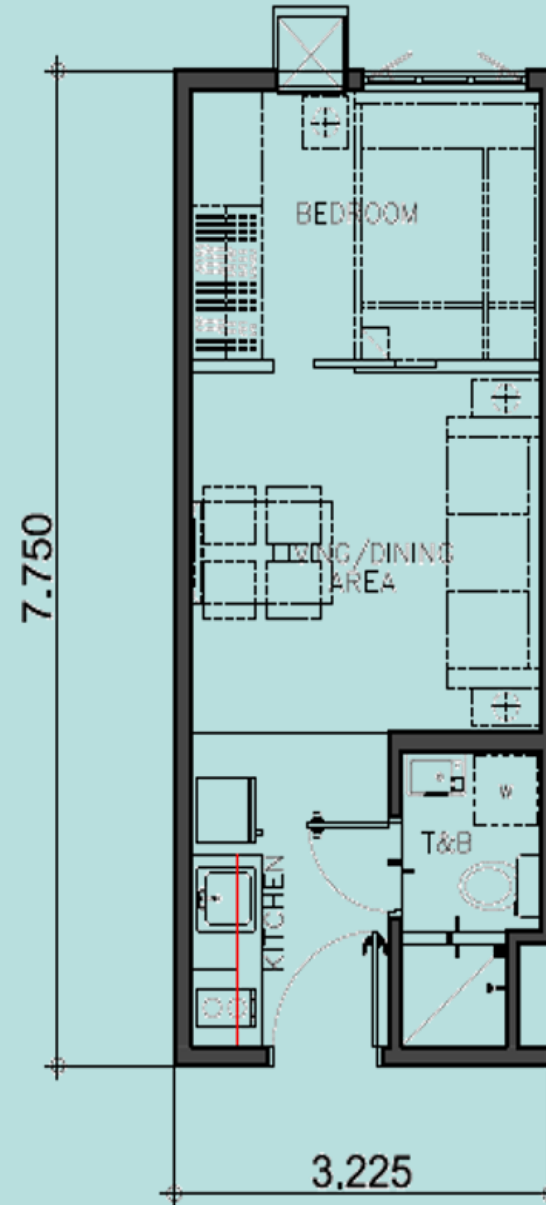

UNIT DELIVERABLES

TYPICAL UNIT FINISHES	
WALL FINISH	Bedroom: Semi-gloss paint finish Living/Dining/Kitchen: Semi-gloss paint finish T&B: Semi-gloss paint finish with 1.2m-high tiles on shower area and tiled baseboard
FLOOR FINISH	Ceramic tiles
DOORS	Bedroom: Laminated Wood Door T&B: PVC Door Main: Laminated Wood Door
WINDOWS	Aluminum Casement Window
TOILET & BATH	Water closet, lavatory, soap holder, tissue holder and shower assembly fixtures
KITCHEN	Polished tiles on concrete kitchen countertop

PROFESSIONAL PROPERTY MANAGEMENT

VAIL
RESIDENCES
CAGAYAN DE ORO CITY

GREENMIST
PROPERTY MANAGEMENT CORP.

SMDC GOOD STAYS



- Quality Customer Service
- Stringent Safety and Security
- First Rate Facility Management
- Spotless Cleanliness
- Transparent Transaction

SMDC Leasing Range of Services:

- Property Listing Management
- Unit viewing arrangements
- Negotiation of lease terms
- Preparation of lease contract
- Tenant move-in assistance

Our commitment to you does not end when we give you the key to your property. We enable you to realize the maximum return of your property investment through SMDC Leasing.

FREQUENTLY ASKED QUESTIONS

Q: Who is the owner and developer of VAIL Residences?

A: SM Development Corporation (SMDC)

Q: What is the ceiling height of the unit?

A: 2.40m – Kitchen and T&B; 2.80m – Other Areas

Q: How many elevators are there?

A: 1 per building (8 people capacity)

Q: How many garbage rooms are there?

A: 1 per level (located at the end of each level)

Q: What are the utility providers:

A: Power: CEPALCO

Water: Cagayan de Oro Water District

Telephone and Internet: TBD

Q: Where can we accept reservations?

A: CDO, Davao, and Manila

Q: How much is the average selling price?

A: P 131,000/ sqm

Q: How much is the reservation fee?

A: P 15,000 (Residential), P 10,000 (Parking)

Q: What is the applicable % for other charges?

A: 8.5%

Q1 STANDARD PAYTERMS

IOM No. SMDC-PDEV-SLSC-IOM-0298

3 Standard Payterms

Building	Payment Scheme	Particular	Discount on TLP	
			Unit	Parking
B-M	Spot Cash	100% Cash in 30 days	10.0%	4.0%
	Spot DP	5% spot / 15% in 35 months / 80% thru Cash or Bank	5.0%	2.0%
	Spread DP	15% over 36 months / 85% thru Cash or Bank	-	-

4 Special Payterms

Building	Payment Scheme	Particular	Discount on TLP	
			Unit	Parking
All Parking	Stretched	100% in 84 months	-	-

RESERVATION FEE (RESIDENTIAL)	₱ 25,000
----------------------------------	----------

RESERVATION FEE (PARKING SLOTS)	₱ 10,000
------------------------------------	----------

CONSTRUCTION UPDATES:

AS OF APRIL 2024



CONSTRUCTION UPDATES:

AS OF NOVEMBER 2023



WHY IS VAIL RESIDENCES THE BEST OPTION?

**Strategic and
Premium
Location**

A safe community

**Complete
Development within
a master-planned
community**

**Sustainable
community. No
Flooding and No
Traffic**

**Strong WIFI
Connectivity**

**Affordable and
Superior Real-Estate
Investment**

THANK YOU AND HAPPY SELLING!

VAIL

RESIDENCES

CAGAYAN DE ORO CITY

For further inquiries, please contact;

ALLEN NESSITAS M. BORJA

Assistant Project Development Manager

Email: allen.borja@smdevelopment.com

Viber: 09566107853

DHSUD PLS No. REM-LS-22-012 (Bldg A to N)

Brgy. Carmen, Cagayan de Oro City

Completion Date: December 2027

Developer: SM Development Corporation